

# MorphoAccess<sup>®</sup> SIGMA Lite Series

## Installation Guide



COPYRIGHT© 2026 IDEMIA  
Osny, France

---

# Warning

---

COPYRIGHT© 2026 IDEMIA. All rights reserved.

Information in this document is subject to change without notice and do not represent a commitment on the part of IDEMIA.

This document contains information of a proprietary nature to IDEMIA and is submitted in confidence for a specific purpose. The recipient assumes custody and control and agrees that this document will not be copied or reproduced in whole or in part, nor its contents revealed in any manner or to any person except to meet the purpose for which it was delivered.

This caveat is applicable to all the pages of this document.

This manual makes reference to names and products that are trademarks of their respective owners.

# Revision History

The table below contains the history of changes made to the present document.

Version	Date	Reference	Description
<b>01</b>	October 2015	2015_0000007248-V1	Document creation
<b>02</b>	December 2015	2015_0000007248-V2	Update Wiegand and DataClock schematic
<b>03</b>	March 2016	2015_0000007248-V3	Add UL information
<b>04</b>	January 2017	2015_0000007248-V4	Change default Ethernet configuration to Static IP address Update sections Bibliography and Support
<b>05</b>	December 2017	2015_0000007248-V5	Update company name (IDEMIA)
<b>06</b>	July 2019	2015_0000007248-V6	CE standard version update p14 Update ANATEL Certification (Brazil) p15 Add RFID information p17
<b>07</b>	May 2020	2015_0000007248-V7	MA SIGMA Lite+ discontinued Update support contacts
<b>08</b>	October 2020	2015_0000007248-V8	Disinfecton and sanitization recommendations
<b>09</b>	December 2020	2015_0000007248-V9	Documents list update
<b>10</b>	June 2023	2015_0000007248-V10	Add in General precautions
<b>11</b>	September	2015_0000007248-V11	Add in General precautions
<b>12</b>	April 2026	2015_0000007248-V11	Add precautions regarding corrosion

# Table of Content

Warning .....	2
Revision History .....	3
Section 1 : Introduction .....	9
<i>MorphoAccess® SIGMA Lite Series terminals</i> .....	10
<i>Scope of the document</i> .....	11
<i>Safety Instructions</i> .....	12
<i>Wiring Recommendations</i> .....	13
<i>Regulatory, safety and Environmental notices</i> .....	14
<i>European Union (CE) regulatory notices</i> .....	14
<i>USA (FCC) regulatory notices</i> .....	15
<i>BRAZIL (ANATEL) regulatory notices</i> .....	15
<i>Canada (IC) regulatory notices</i> .....	16
<i>UL information</i> .....	16
<i>RFID information</i> .....	17
<i>Others recommendations</i> .....	17
<i>Recommendations for terminal implementation</i> .....	18
Section 2 : General Description .....	21
<i>Box opening</i> .....	22
<i>Components of the initial package</i> .....	23
<i>Terminal's front view description</i> .....	24
<i>Terminal's rear view description</i> .....	25
<i>MorphoAccess® SIGMA Lite Series Technical Characteristics</i> .....	26
Section 3 : Installation Procedure.....	28
<i>Before proceeding to the installation</i> .....	29
<i>Installation</i> .....	30
<i>Required tools (not supplied)</i> .....	30
<i>Equipment from the initial package to use</i> .....	30
<i>Step by step procedure</i> .....	31
Section 4 : Electrical Interface .....	34
<i>Wiring overview</i> .....	35
<i>Power Supply</i> .....	36
<i>External Power supply</i> .....	36
<i>POE (Power Over Ethernet)</i> .....	36

---

Output Relay .....	37
Nominal characteristics of relay.....	37
Example of connection for electrical door locks.....	38
Tamper Switch.....	39
Operating principle for the switch.....	39
Nominal characteristics of switch block.....	39
Wiegand port wiring .....	40
Wiegand input wiring.....	40
Wiegand output wiring .....	41
The controller supports neither LED1 nor LED2 signals.....	42
The controller supports only LED1 signal .....	42
The controller supports LED1 and LED2 signals .....	42
Data Clock Input .....	43
Data Clock Output .....	44
RS-485 port wiring.....	45
GPIO wiring .....	46
Single Door Access Control (SDAC) implementation .....	47
Ethernet connection.....	48
Default Ethernet configuration .....	48
Recommendations for RJ45 wiring.....	49
External USB connection .....	51
Wi-Fi™ dongle installation .....	52
Section 5 : User Interface .....	53
Modes for controlling access rights .....	54
Introduction.....	54
Identification mode .....	54
Authentication (verification) mode .....	54
Multi-factor mode .....	55
Proxy mode.....	55
External database mode (also called polling mode) .....	55
Configuring the terminal.....	57
MorphoAccess® 500 or J Series legacy mode.....	57
Bioscrypt 4G Series legacy mode.....	57
MorphoAccess® SIGMA Lite Series native mode .....	58
Anti-tamper / anti-pulling switches .....	59
Section 6 : Accessories, Software Licenses and PC Applications.....	60

---

Compatible Accessories, Licenses and Software .....	61
Compatible PC applications .....	62
Section 7 : Recommendations .....	63
Global warning .....	64
General precautions .....	64
Areas containing combustibles.....	64
Specific precautions for terminals equipped with a contactless smartcard reader .....	64
Ethernet connection .....	65
Date / Time synchronization .....	65
Cleaning precautions .....	65
Disinfection and sanitization recommendations .....	65
Legacy mode.....	66
Main principles.....	70
Most useful areas for biometric data.....	71
Position of finger.....	72
Finger height.....	72
Finger angle.....	72
Finger inclination .....	73
Finger rotation.....	73
Troubleshooting .....	74
How to get the latest versions of documents .....	76
Documents concerning the MorphoAccess® terminal .....	77
Troubleshooting .....	79
The terminal IP address is unknown or it is not possible to connect to the terminal.....	79
The sensor is switched off.....	79
The terminal returns erratic responses to Ping commands .....	79
Technical Support and Hotline .....	80
North America .....	80
South America .....	80
Asia, Pacific.....	80
Europe, Middle East and Africa .....	80
Web site.....	80

---

Annex 1 : Finger Placement Recommendations.....	69
Annex 2 : Bibliography .....	75
Annex 3 : Support .....	78

---

# Table of Figures

---

Figure 1: Implementation Recommendations.....	19
Figure 2: Box Opening.....	22
Figure 3: Box Content .....	23
Figure 4: MorphoAccess® SIGMA Lite Series terminal front view.....	24
Figure 5: MorphoAccess® SIGMA Lite Series terminal rear view .....	25
Figure 6: Removing wall frame .....	29
Figure 7: Drilling template .....	31
Figure 8: Wall plate fixing .....	32
Figure 9: Cabling layout .....	35
Figure 10: Power supply wiring .....	36
Figure 11: Output relay wiring.....	37
Figure 12: Example of electric door strike connection.....	38
Figure 13: Tamper switch wiring .....	39
Figure 14: Wiegand input wiring .....	40
Figure 15: Wiegand output wiring.....	41
Figure 16: Wiegand port wiring – DataClock.....	43
Figure 17: Wiegand port wiring – Data Clock.....	44
Figure 18: RS-485 port wiring – RS485 .....	45
Figure 19: GPIO wiring .....	46
Figure 20: SDAC wiring.....	47
Figure 21: Direct Point to Point Ethernet Connection.....	49
Figure 22: RJ45 wiring.....	50
Figure 23: External USB connection .....	51
Figure 24: Wi-Fi™ dongle installation .....	52



## MorphoAccess® SIGMA Lite Series terminals

Congratulations for choosing a MorphoAccess® SIGMA Lite Series Automatic Fingerprint Recognition Terminal.

MorphoAccess® SIGMA Lite Series provides an innovative and effective solution for access control applications using Fingerprint Verification or/and Identification.

Among a range of alternative biometric technologies, the use of finger imaging has significant advantages: each finger constitutes an unalterable physical signature, developed before birth and preserved until death. Unlike DNA, a finger image is unique to each individual - even identical twins.

MorphoAccess® SIGMA Lite Series integrates Morpho image processing and feature matching algorithms. This technology is based on lessons learned during 25 years of experience in the field of biometric identification and the creation of literally millions of individual fingerprint identification records.

We believe you will find the MorphoAccess® SIGMA Lite Series fast, accurate, easy to use and suitable for physical access control.

The MorphoAccess® SIGMA Lite Series offers the following advantages:

- high quality optical sensor (IQS quality sensor),
- supports multiple input/output interfaces used in the physical access control industry,
- Local Area Network interface for easy interaction with other host systems ; LAN and WLAN possibilities (Wi-Fi™ as an option),
- compact size for easy installation and integration into your available office space,
- intuitive man machine interface with touch panel and display, that is easy to use in both setup and operational modes,

To ensure the most effective use of your MorphoAccess® SIGMA Lite Series terminal, we recommend that you read this Installation Guide completely.

## Scope of the document

This guide deals with the installation of MorphoAccess® SIGMA Lite Series, which is made up of following list of products:

MA SIGMA Lite Series Marketing Name	Biometrics	Contactless smartcard reader			Touch screen	Water Resistant	Regulatory Model Number (*)
		iCLASS®	MIFARE® DESFire®	Prox®			
MA SIGMA Lite	✓					✓	MPH-AC001C
MA SIGMA Lite iClass	✓	✓				✓	MPH-AC001B
MA SIGMA Lite Multi	✓		✓			✓	MPH-AC001B
MA SIGMA Lite Prox	✓			✓		✓	MPH-AC001A
MA SIGMA Lite+	✓				✓	✓	MPH-AC001C
MA SIGMA Lite+ iClass	✓	✓			✓	✓	MPH-AC001B
MA SIGMA Lite+ Multi	✓		✓		✓	✓	MPH-AC001B
MA SIGMA Lite+ Prox	✓			✓	✓	✓	MPH-AC001A

(\*) The Regulatory Model Number is the main product identifier in the regulatory documentation and test reports associated to the product

### NOTE:

- *MA stands for MorphoAccess®*
- *MA SIGMA Lite+ was discontinued*

## Safety Instructions

  
 means Direct Current (DC)

The installation of this product should be made by a qualified service Person and should comply with all local regulations.

It is strongly recommended to use a class II power supply at 12VDC 1A minimum or at 24VDC 500mA minimum in conformity with Safety Electrical Low Voltage (SELV). The power supply cable length should not exceed 10 meters.

This system must be installed in accordance with the National Electrical Code (NFPA 70), and the local authority having jurisdiction.

This product is intended to be installed with a power supply complying with IEC60950-1, in accordance with the NEC Class 2 requirements; or supplied by a listed IEC60950-1 external Power Unit marked Class 2, Limited Power source, or LPS and rated 12VDC, 1A minimum or 24VDC, 0,5A minimum.

For UL 294 Compliance, power supply must be UL294B or UL 294 Listed Class 2 with a power limited output.

In case of building-to-building connection (power source in a building, and terminal in another building), it is recommended to connect the 0V of the power supply to the earthing system of the building. And the terminal block Power Ground must be connected with the earthing system of the other building.

Note that all connections of the MorphoAccess® SIGMA Lite Series terminal described hereafter are of SELV (Safety Electrical Low Voltage) type.

## Wiring Recommendations

IDEMIA recommends using a gauge AWG20 for 12VDC power supply (when the terminal is not powered using POE feature).

The voltage must be measured on the product block connector and must be equal to 12VDC-24VDC (-15% / +10%)

For information, this table shows the maximum drop voltage observed on the terminal MorphoAccess® SIGMA Lite Series, depending on the length of the cable:

Gauge AWG	Diameter (mm)	Maximum drop voltage @ 1m (V)	Maximum drop voltage @ 5m (V)	Maximum drop voltage @ 10m (V)
<b>20</b>	0.81	0.03	0.17	0.33
<b>22</b>	0.64	0.05	0.26	0.53
<b>24</b>	0.51	0.08	0.42	0.84

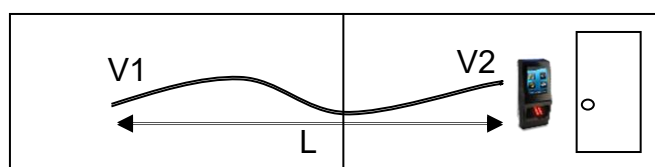

Drop voltage = loss of power due to wire resistance and its length:

$$V2 = V1 - \text{Drop voltage}$$

## Regulatory, safety and Environmental notices

### European Union (CE) regulatory notices

#### *Declaration of Conformity*



Products bearing the CE marking comply with one or more of the following EU Directives as may be applicable:

- EMC Directive 2014/30/EU.
- RED Directive 2014/53/EU.
- ROHS Directive 2011/65/EU.
- ECODESIGN Directive 2009/125/EC.

Compliance with these directives is assessed using applicable European Harmonised Standards.

MorphoAccess® SIGMA Lite Series are intended to be used for professional application only (buildings, airport...).

The full Declaration of Conformity is available on demand to your reseller. Please, provide him the product model name or its Regulatory Model Number (Model on the label).

#### *Products with wireless features (EMF)*

This product meets the provisions of the EU's Council recommendation 1999/519/EC on the limitation of the exposure of the general public to electromagnetic fields (0 Hz to 300 GHz).

## USA (FCC) regulatory notices



**This device complies with part 15 of the FCC Rules. Operation is subject to the following two conditions: (1) this device may not cause harmful interference, and (2) this device must accept any interference received, including interference that may cause undesired operation.**

Changes or modifications not expressly approved by the party responsible for compliance could void the user's authority to operate the equipment.

Responsible Party:

**IDEMIA**

**2, place Samuel de Champlain**

**92400 Courbevoie - France**

**NOTE:** *This equipment has been tested and found to comply with the limits for a Class B digital device, pursuant to Part 15 of the FCC Rules. These limits are designed to provide reasonable protection against harmful interference in a residential installation. This equipment generates, uses and can radiate radio frequency energy and, if not installed and used in accordance with the instructions, may cause harmful interference to radio communications. However, there is no guarantee that interference will not occur in a particular installation. If this equipment does cause harmful interference to radio or television reception, which can be determined by turning the equipment off and on, the user is encouraged to try to correct the interference by one of the following measures:*

- Reorient or relocate the receiving antenna.
- Increase the separation between the equipment and receiver.
- Connect the equipment into an outlet on a circuit different from that to which the receiver is connected.
- Consult the dealer or an experienced radio/TV technician for help.

Shielded cables must be used with this unit to ensure compliance with category B FCC restrictions.

## BRAZIL (ANATEL) regulatory notices

(Applicable only to LITE+ versions / Aplicável apenas às versões LITE+)



Este equipamento não tem direito à proteção contra interferência prejudicial e não pode causar interferência em sistemas devidamente autorizados

## Canada (IC) regulatory notices

### WARNING TO USERS IN THE CANADA / ATTENTION POUR LES UTILISATEURS AU CANADA

This device complies with Industry Canada license-exempt RSS standard(s), and with ICES 003 standard for version(s) without RFID reader. Operation is subject to the following two conditions: (1) this device may not cause interference, and (2) this device must accept any interference, including interference that may cause undesired operation of the device.

Under Industry Canada regulations, this radio transmitter may only operate using an antenna of a type and maximum (or lesser) gain approved for the transmitter by Industry Canada.

To reduce potential radio interference to other users, the antenna type and its gain should be so chosen that the equivalent isotropically radiated power (e.i.r.p.) is not more than that necessary for successful communication.

Note : UL LLC has not verified this product for compliance in respect to Canadian standards.

## UL information

### UL 294 Performance levels

	Access Control Line Security Level	Destructive Attack Level	Endurance Level	Stand-by Power Level	Conditions
MorphoAccess® Sigma Lite (MPH-AC001C)	Level I	Level I	Level IV	Level I	NA
MorphoAccess® Sigma Lite iCLASS (MPH-AC001B)					
MorphoAccess® Sigma Lite Multi (MPH-AC001B)					
MorphoAccess® Sigma Lite Prox (MPH-AC001A)					
MorphoAccess® Sigma Lite + (MPH-AC001C)					
MorphoAccess® Sigma Lite + iCLASS (MPH-AC001B)					
MorphoAccess® Sigma Lite + Multi (MPH-AC001B)					
MorphoAccess® MA Sigma Lite + Prox (MPH-AC001A)					
All models may be suffixed with a "WR"					

## RFID information

Frequency band for RFID 13.56MHz : 13.553–13.567 MHz

Associated RF power: -2.91dB $\mu$ A/m at 10m

Frequency band for RFID 125kHz : 119kHz – 135kHz

Associated RF power: -11.31 dB $\mu$ A/m at 10m

## Others recommendations

### *Potential safety conditions notice*

If you notice any of the following conditions (or if you have other safety concerns), do not use the product: crackling, hissing, or popping sound, or a strong odor or smoke coming from the product. It is normal for these conditions to appear when an internal electronic component fails in a safe and controlled manner. However, these conditions may also indicate a potential safety issue. Do not assume it is a safe failure. Turn off the product, disconnect it from its power source, and contact technical support for assistance.

### *Disposal of waste equipment by users*



This symbol means do not dispose of your product with your other household waste. Instead, you should protect human health and the environment by handing over your waste equipment to a designated collection point for the recycling of waste electrical and electronic equipment.

## Recommendations for terminal implementation

Every installation is unique. Sometimes the issues are well defined and can be handled in a standard fashion; sometimes the issues are very specific and may not be immediately recognizable.

IDEMIA recommends following these steps for a successful installation:

- **Plan the installation** - Choose the type of hardware required, decide if a network is required, and decide on the location and number of required terminals.
- **Unpack all items** - Unpack all items and check against the packing list.
- **Install network hardware components** - Install the cabling and components needed to run the system.
- **Install software** - Install the software needed to set up the terminals.
- **Pre-configure device** - Connect the terminals to the Ethernet, supply power to the terminals, and pre-configure the terminals.
- **Mount devices** - Mount the terminals in their final locations
- **Power distribution and device hook up** - Connect the terminals wiring via the back panel.
- **Power-up procedure** - Check the power connections, and then start the system safely.

To secure properly an access, IDEMIA recommends installing the MorphoAccess® SIGMA Lite Series terminal as a part of the typical Access Control environment, as the one described in the figure below.

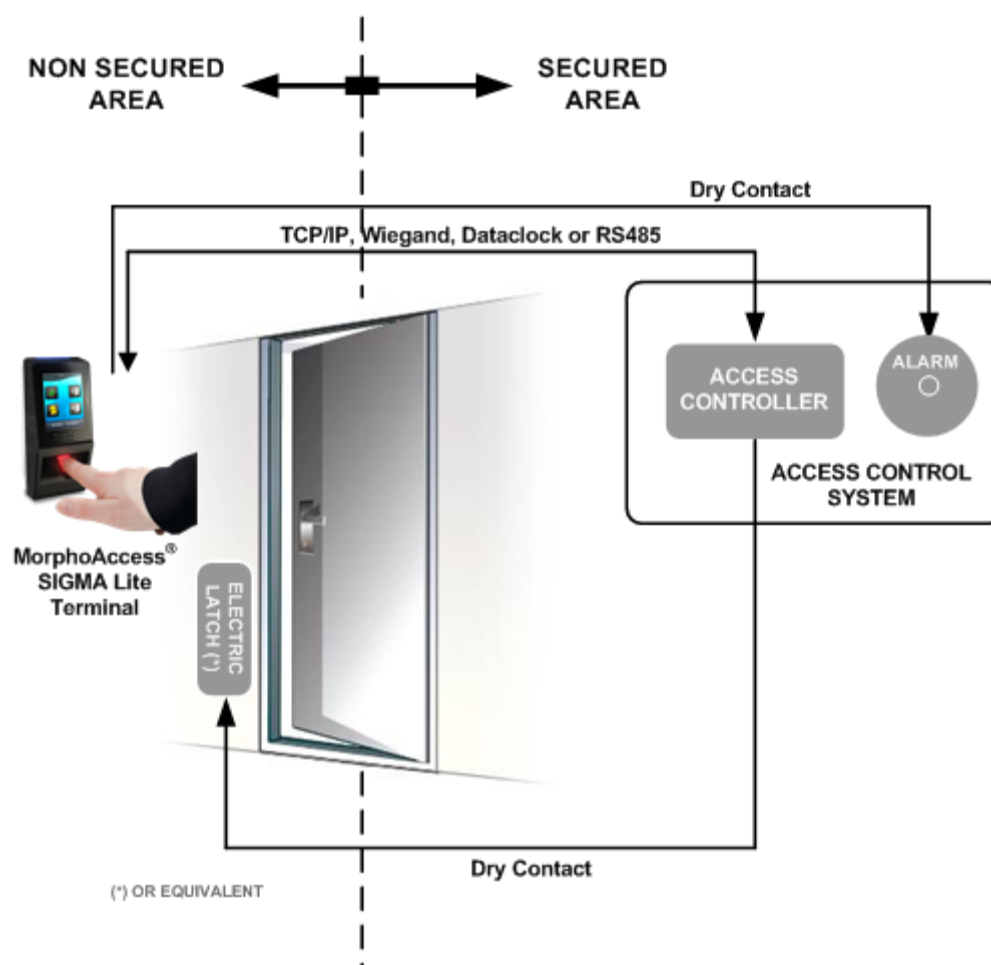

**Figure 1: Implementation Recommendations**

This environment comprises:

### ***The MorphoAccess® SIGMA Lite Series terminal itself***

Its role is to perform one-to-many biometric identification or one-to-one biometric verification, i.e. to identify the individual who is presenting his finger on the terminal sensor by comparing his biometric data with the references previously stored in the terminal database (in the form of biometric templates) or to verify his identity using the reference stored in a contactless card presented to the terminal.

### ***An Access Controller (3rd party product)***

The Controller is the element which controls the access rights of the individuals to the secured area. For that reason, it must be located in the secured area.

The individuals who are authorized to access the secured area have their User ID listed in a so-called "authorized user List" (in contrast with a banned card list).

The MorphoAccess® SIGMA Lite Series terminal and the Controller are communicating using one of the available protocol (TCP/IP, Wiegand or Dataclock, or RS485). The typical process is described below:

- After access request, and local checks, the MorphoAccess® SIGMA Lite Series terminal sends the User ID, and the result of local checks, to the Controller
- The Controller performs additional checks, and sends its decision to the MorphoAccess® SIGMA Lite Series terminal (which displays access granted or access denied depending on the answer), and to the electric latch of the door (though a door controller) if access is granted to the user
- The MorphoAccess® SIGMA Lite Series terminal sends an alarm signal to the Controller as soon as a malicious operation is detected (terminal pulled out from the wall or opened); please refer to the paragraph dealing with anti-pulling and anti-tamper switches for more explanations.

The Controller is part of the global Access Control System of the secured area, which can provide useful features such as manage:

- authorized user lists (i.e. for VIP),
- banned card lists (i.e. for lost user cards),
- an access request log (who and when, access granted or denied,..),
- an event log (i.e. tamper detection, access control for evacuation of the building,...).

The MorphoAccess® terminal is able to work alone, without Controller, but the protection level of the secured area is lower.

Note: For UL compliance only the Wiegand protocol was verified.

### ***An Alarm (3rd party product)***

This element is connected to the MorphoAccess® SIGMA Lite Series terminal through a dry contact.

The MorphoAccess® SIGMA Lite Series terminal sends the command to activate the Alarm as soon as a malicious operation (terminal pulled out from the wall or having its bottom cover opened out of maintenance operations) is detected; please refer to the paragraph dealing with anti-pulling and anti-tamper switches for more explanations.

### ***A Electric door strike or equivalent (3rd party product)***

The activation of this element, open the door or the gate, to provide the physical access to the protected area. The Controller is the one which sends the command to activate the strike if access is granted (i.e. if the individual's User ID is listed in the Controller authorized user List). Connection between these two elements is done through a dry contact.

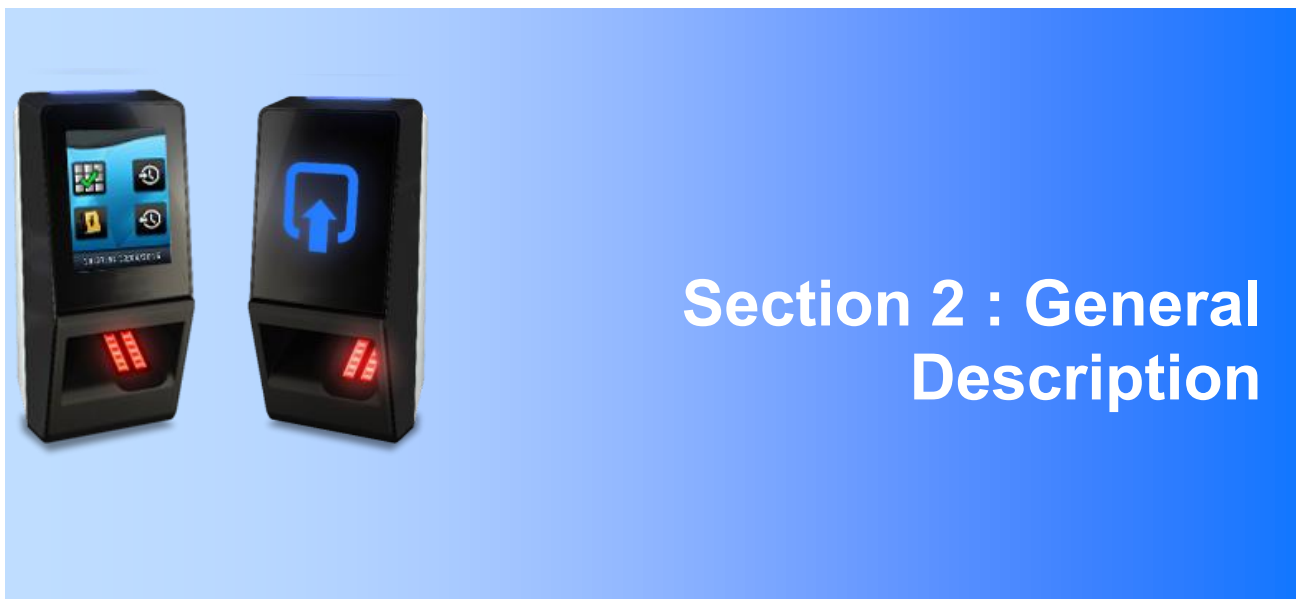

## Box opening

At the box opening, components shall be extracted from the protection casing as depicted in the pictures below.

Extract the wall plate (which is not screwed to the terminal) and keep it separate until the installation of the terminal is completed. The screwing of the product to the wall plate is the last stage of the installation.

The protection accessory provided is optional: it is recommended in case of outdoor installation (to protect biometric module against dust, rain and direct sun rays).

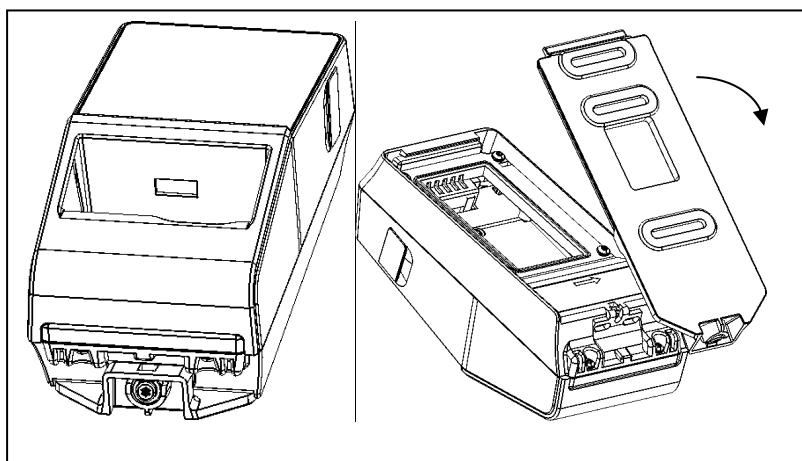

Figure 2: Box Opening

## Components of the initial package

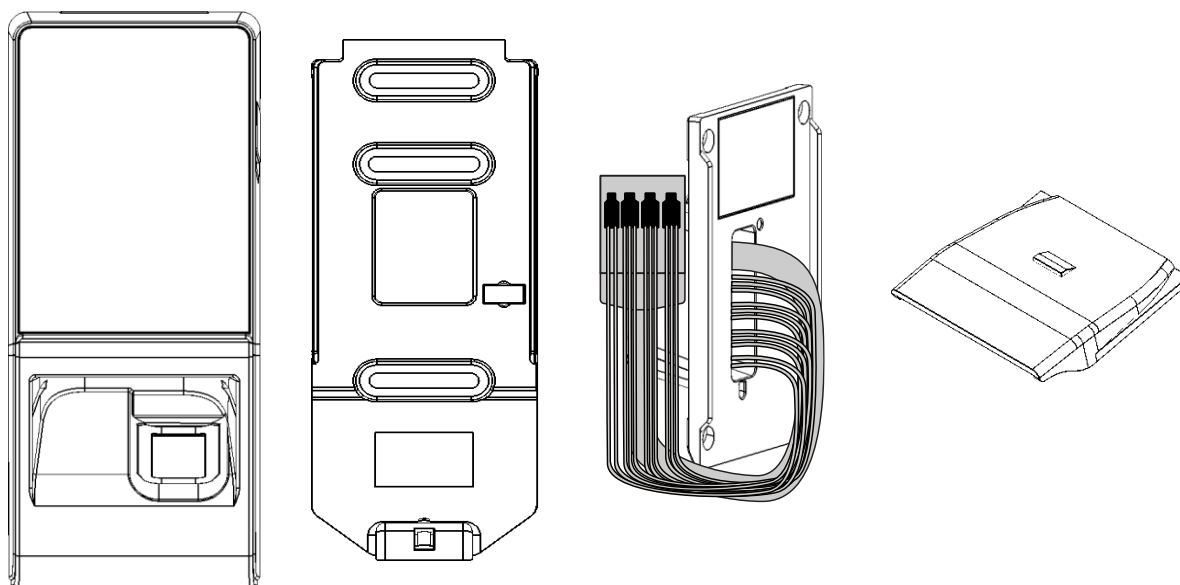

Figure 3: Box Content

1. One (1) Terminal's body
2. One (1) Wall frame
3. One (1) Pre-wired back door
4. One (1) Protection accessory (optional) to insert over the biometric sensor

## Terminal's front view description

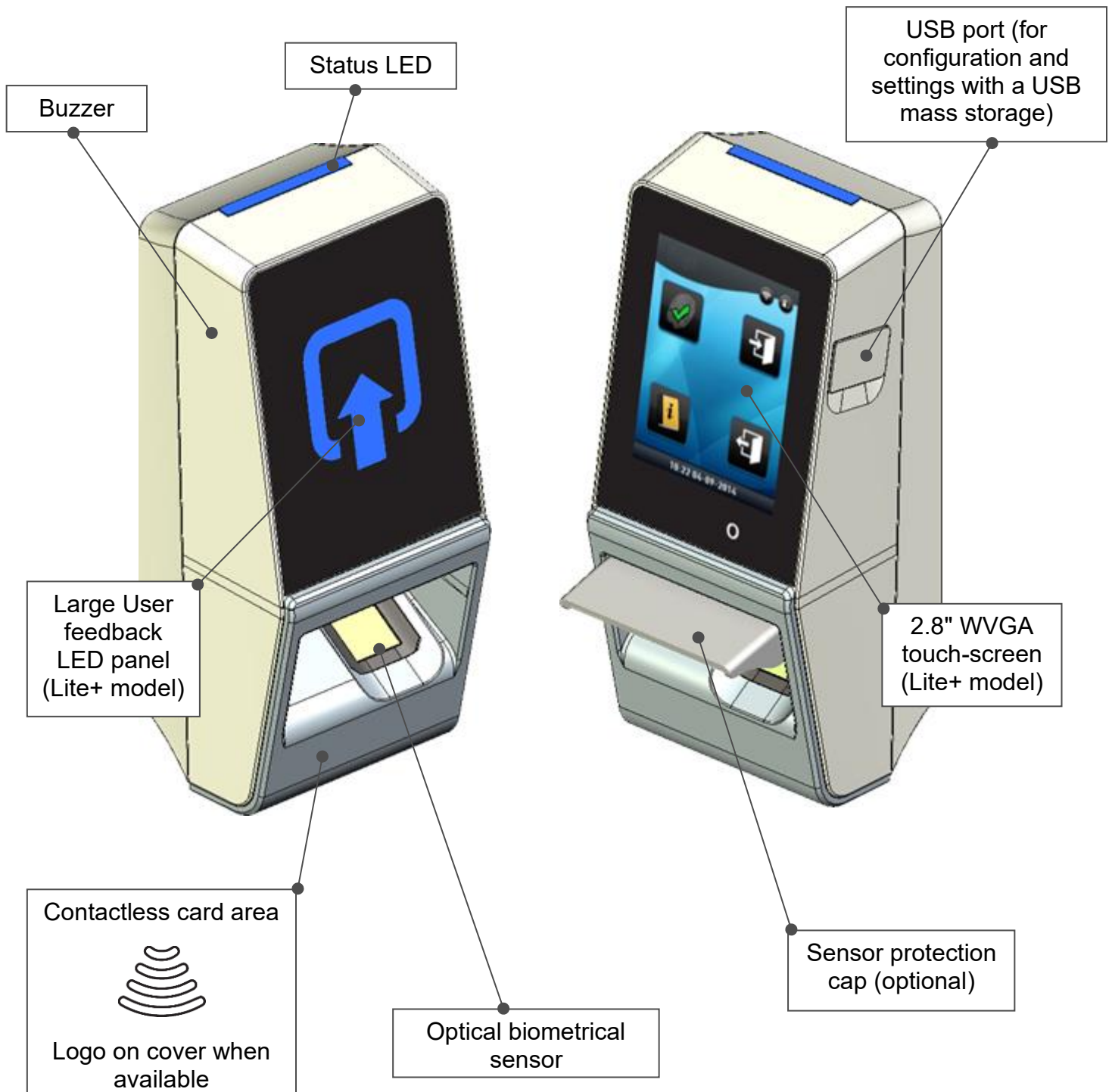

Figure 4: MorphoAccess® SIGMA Lite Series terminal front view

## Terminal's rear view description

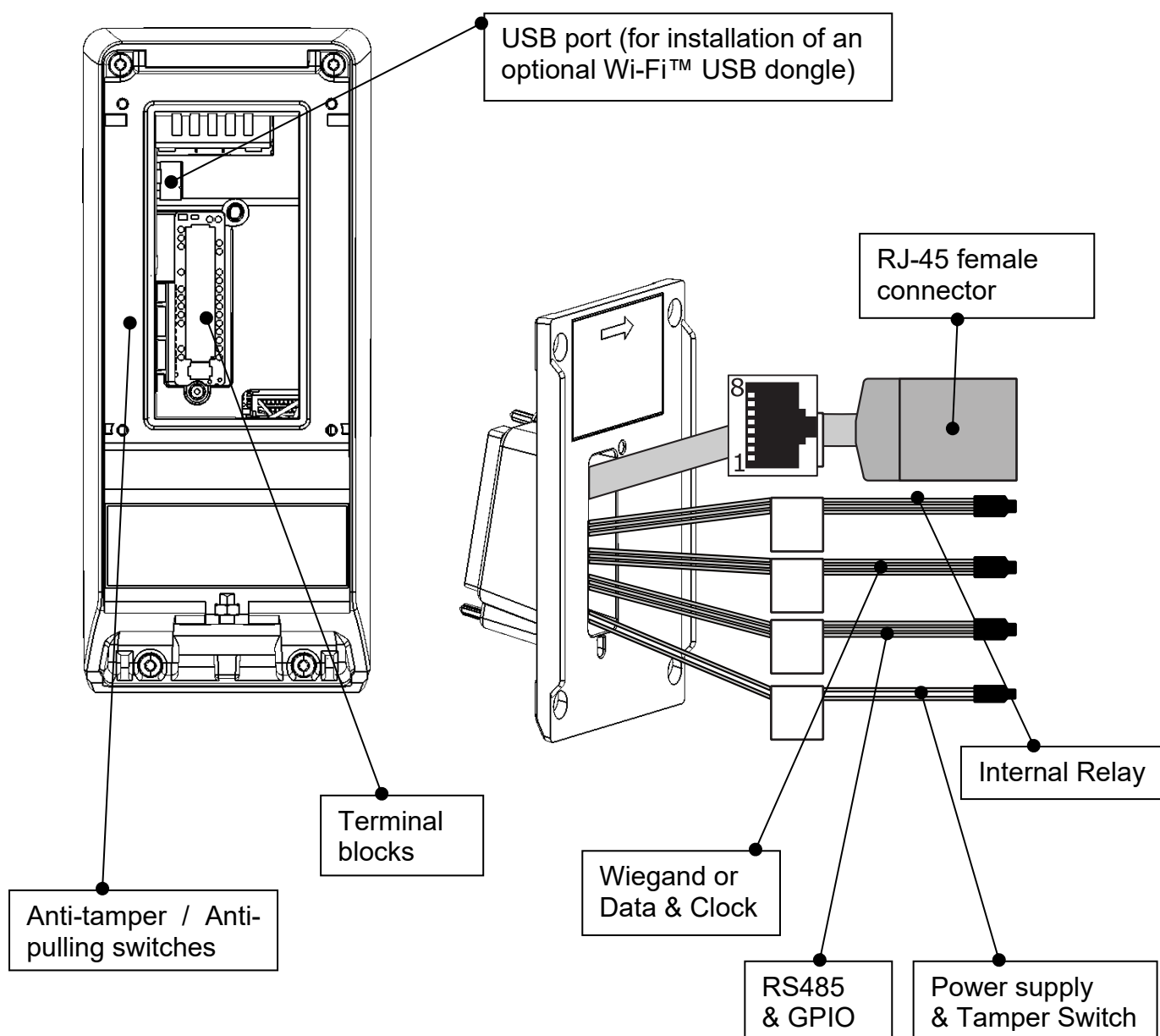

Figure 5: MorphoAccess® SIGMA Lite Series terminal rear view

## MorphoAccess® SIGMA Lite Series Technical Characteristics

Item	Description
Access control modes	Identification (search for fingerprint in a local database)
	Authentication with contactless smartcard, with or without fingerprint check (only if terminal is equipped with a contactless smartcard reader)
	Multi-factor: identification or authentication (only if terminal is equipped with a contactless smartcard reader)
	Proxy: the access control check is fully driven by a remote system
Man Machine Interface	2,8" WVGA color touchscreen LCD (Lite+ model only)
	Buzzer
Biometrics	Morpho Compact Biometric Module inside: 500dpi, 256 gray levels optical sensor. FBI PIV IQS quality sensor.
	False Acceptance Rate (FAR) adjustable from 1% down to 10 <sup>-7</sup> %
	Database capacity: 500 users (standard) and up to 10 000 users (with specific license).
Log capacity	100 000 records (standard) and up to 1 000 000 (with specific license)
LAN/WLAN connection	For terminal configuration and data transfer: Ethernet 10/100 Base T (MDI, MDI-X) Or Wi-Fi™ Wireless LAN (option), WEP, WPA (PSK) and WPA2 (PSK) encryption available Either TCP, TLS or SSL protocol
RFID cards (depending on product version)	MIFARE® 1k, 4k MIFARE® PLUS S (SL1, SL3) 2k, 4k
	DESFire® 2k, 4k, 8k
	HID iCLASS® 16kb, 32kb
	HID Prox

Serial port	The serial port supports WIEGAND, DATACLOCK (ISO2) and RS485 protocols
Output relay switches	Access granted: 1 switch two outputs (normally “open” and normally “closed”) 30V – 1A max (Resistive/inductive loads)
USB host port	External port for terminal configuration through a USB mass storage key Internal port to connect an external Wi-Fi™ USB dongle using an adapter cable.
Input signals	LED1/LED2 to activate the access granted relay
Power supply	12 to 24 V DC power supply (1A min @12V) Or by Power Over Ethernet through RJ-45 connector Note for UL 294 Compliance power supply shall be UL 294 and UL 294B with power limited output.
Security of the terminal	Anti-tamper-pulling switches. Tamper-pulling detection: one relay switch.
Size and weight	W x H x D: 68mm x 156mm x 62mm (2.68” x 6,14” x 2,44”) Weight : 280g
Environmental conditions	Operating temperature -10 °C to + 55 °C (14°F to 131°F)
	Operating humidity 10 % < RH < 80 % (non condensing)
	Storage temperature -25 °C to + 70 °C (-13°F to 158°F)
	Storage humidity 5% < RH < 95 %
	IP65 (once back door attached with the 4 screws) For UL 294 Compliance the unit is rated for indoor use only. IP65 was not verified by UL.
	The terminal should be installed in controlled lighting conditions. Avoid direct exposure to sunlight or to UV lights.
Certifications	CE, IEC 60950-1, FCC Part 15, RSS210 - Issue 8 : 2010, RSS-102 - Issue 5 : 2015, RSS-Gen – Issue : 2014, RoHS, REACH, WEEE



## Before proceeding to the installation

- Make sure that you have all the components described in “Components of the initial package” section at your disposal.
- Remove the wall plate. Keep this element at hand.

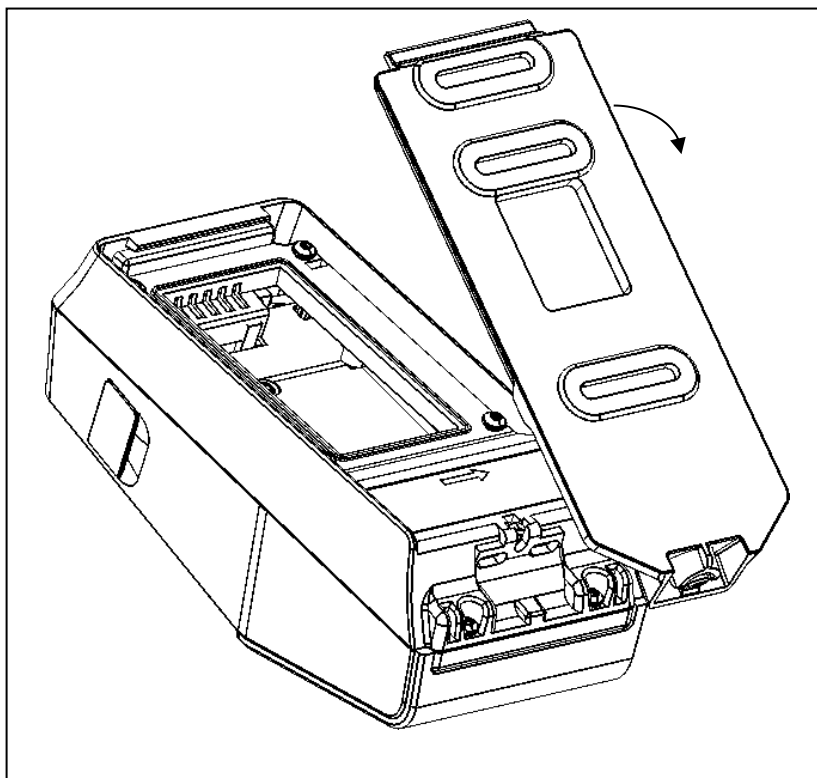

Figure 6: Removing wall frame

It is then possible to fix wall plate on the wall.

The recommended height for fixing of the terminal is 1.40m (top of the product).



**For an optimal use the terminal must be installed in an area where the lighting conditions are controlled. Avoid direct exposure of the sensor to the sun light.**

## Installation

### Required tools (not supplied)

- Two (2) raw plugs + Two (2)  $\varnothing$  4mm max and length 30mm screws.
  - One (1) screwdriver adapted to screws above.
  - One (1) Drill (with a drill bit diameter adapted to raw plugs above).
  - One (1) hole saw (depending on installation case).
  - A (1) Torx T10 screwdriver
- 
- Deadbolt/door strike
  - Snubber diode required to protect regulated DC power supply from inductive kickback (1N4007 diode or equivalent recommended)
  - Separate power supply for the deadbolt/door strike based on supplier's recommendations.
  - External relay (if required)
  - Networking cable





For UL-294 compliance, an earthed screen in the wire or around all wires to/from product is only required when the wires share space/compartments/tube with high voltage cables.

### Equipment from the initial package to use

- One (1) Terminal's body,
- One (1) pre-wired back door,
- One (1) wall plate,
- One (1) Protection accessory (optional) to insert over the biometric sensor

## Step by step procedure

The recommended height for fixing of the terminal is 1.40m (top of the product).

-  For an optimal use the terminal must be installed in an area where the lighting conditions are controlled. Avoid direct exposure of the sensor to the sun light.
-  Power supply from electrical source shall be switched off before starting the installation.
-  The strength of the attachment depends on the solidity of the wall on which the terminal is mounted.
-  To ensure water tightness, the pre-wired back door has to be attached to the product with the 4 screws (refer to corresponding picture for process).

### Drilling the mounting holes

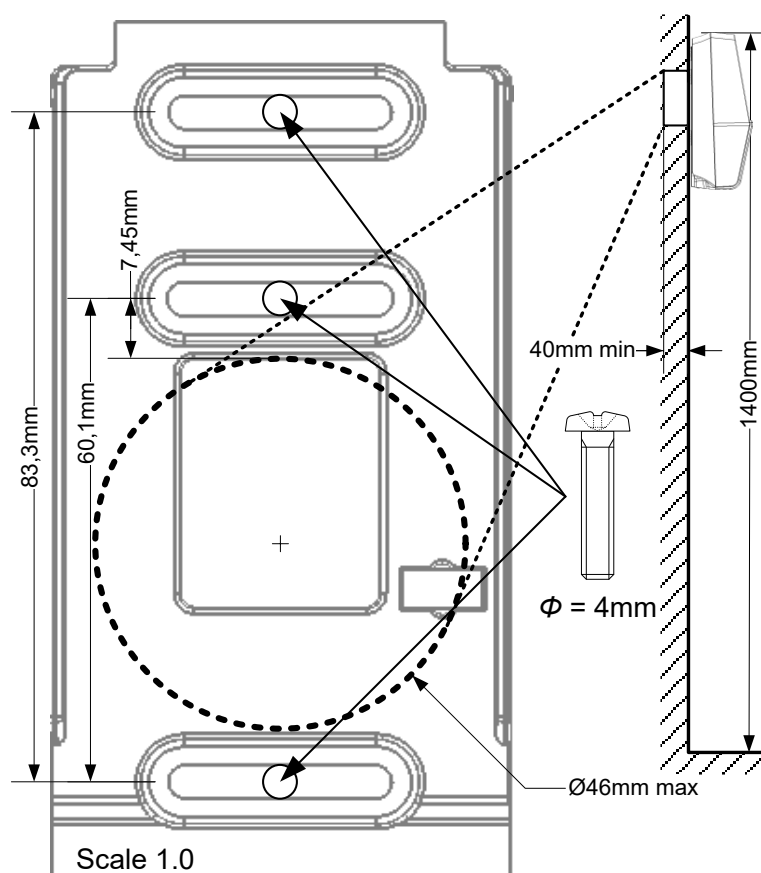

Figure 7: Drilling template

If not present, drill in the wall a hole with a diameter adapted to the width of the terminal and the cable to be hosted in (see Figure 7: Drilling template. This template at scale 1:1 can be found in the Quick Installation Guide).

Confirm the presence inside the hole of all the cables needed for the electrical installation (see Electrical Interface)

Drill in the wall 2 holes with a diameter adapted to screws and fit them with the raw plugs (see Figure 7: Drilling template).

### Fixing



**Be sure that a sufficient space is reserved in the wall for the passage of cables, in particular for Ethernet cable and plug, and also for the Wi-Fi dongle (if applicable).**

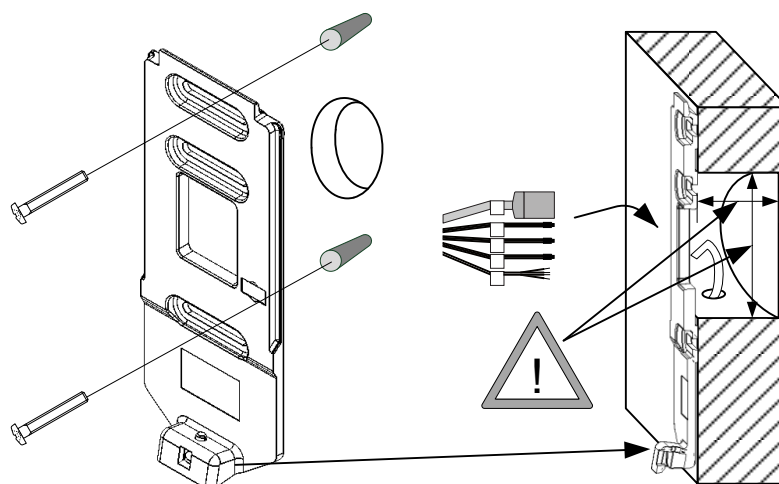

**Figure 8: Wall plate fixing**

Place the wall plate against the wall, opposite the four holes pierced in the wall (see Figure 8: Wall plate fixing).

Screws are compliant with NF EN ISO 3506-4 , which "specifies the mechanical properties of tapping screws made of austenitic, martensitic and ferritic steel grades of corrosion-resistant stainless steels, when tested over an ambient temperature range of 10 °C to 35 °C".

### Cabling

Cable for wiring shall be AWG 20 to 24, length shall be adapted to the size of the hole in the wall, to terminal connections, and to the distant between the electric source and the terminal itself.

---

## Closing

Power has to be set up just after closing it. If product has to be stored for a long time (more than 48 hours), don't forget to restore its configuration before use.

Finally, lock the product with the screw at the bottom of the terminal.



## Wiring overview



Before proceeding, make sure that the person in charge of installation and connections is properly connected to earth, in order to prevent Electrostatic Discharges (ESD).



Power supply ground shall not be used for peripheral ground. All other grounds can be used indifferently.

Note that all connections of the MorphoAccess® SIGMA Lite Series terminal described hereafter are of SELV (Safety Electrical Low Voltage) type.

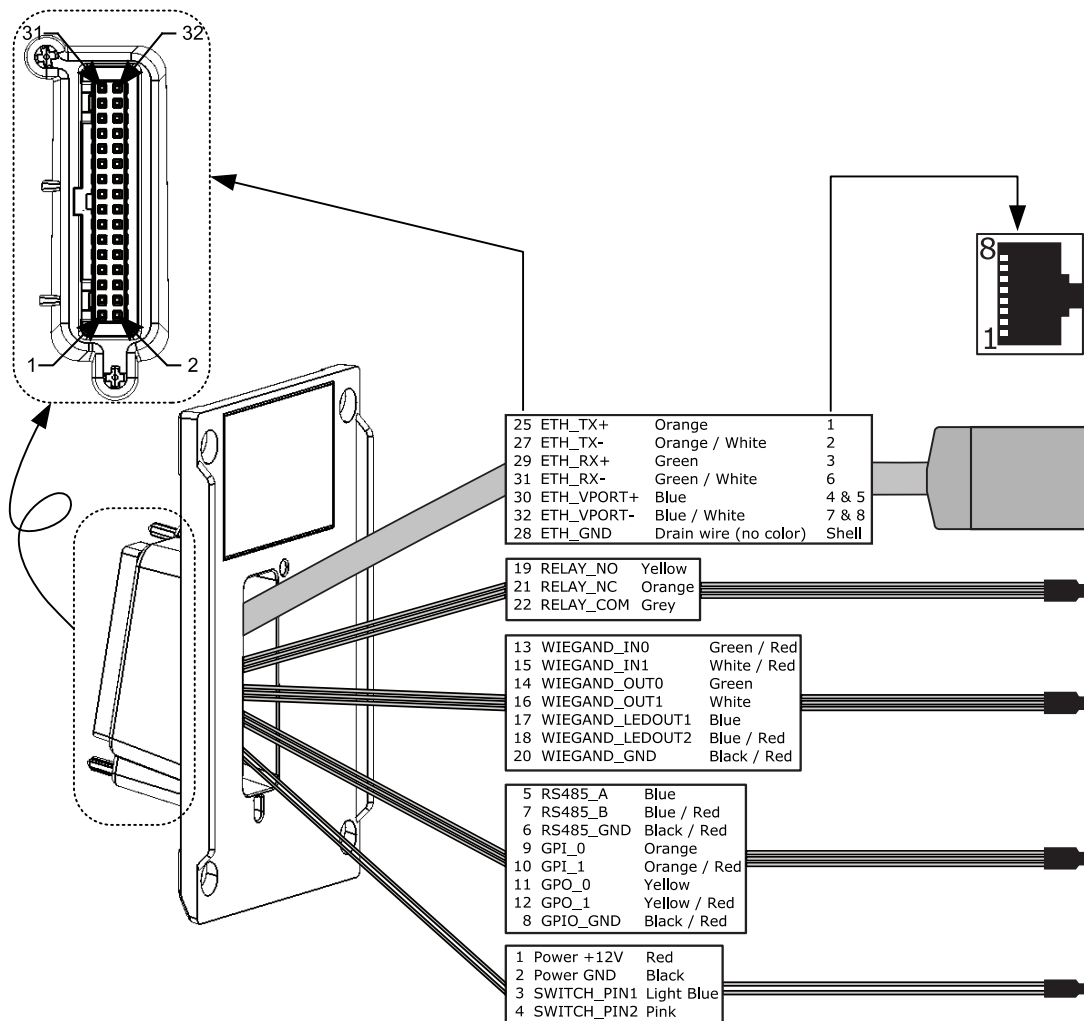

Figure 9: Cabling layout

## Power Supply

POE and external power supply can be used simultaneously, but when both power supplies are available, priority is given to external power supply. If the external power supply fails or is shut down, the terminal will go off and then restart using POE.

### External Power supply

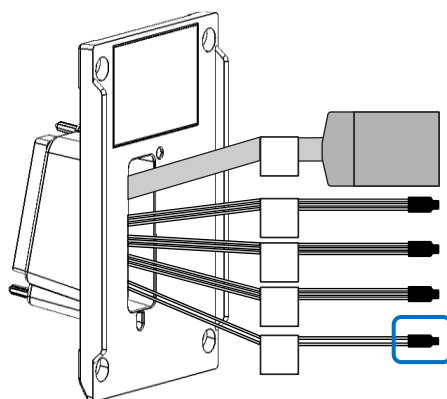

Figure 10: Power supply wiring

1	Red	Power Supply 12-24V DC	In	Positive 12-24 Volts, power supply
2	Black	Power ground	In	Ground power supply

### External power supply

- Must comply with IEC 60950-1 standard.
- 12V to 24V Dc (regulated and filtered) 1 Amp min at 12V.
- Could be provided by a 12 Volts Wiegand power supply, which complies with the Security Industry Association's Wiegand standard March 1995.
- If sharing power between devices, each unit must receive 1A (e.g. two units would require a 12vDC, 2A supply)

### POE (Power Over Ethernet)

MorphoAccess® SIGMA Lite Series terminal's power supply can also be provided by the Ethernet using RJ45 connection (Power Over Ethernet mode - IEEE802.3af or IEEE802.3at type 1 compliant).

The terminal maybe alternatively be powered via a UL 294B PSE PoE Limited power source. UL 294 compliance was verified with POE (PSE-Power Sourcing Equipment model Phihong part number PSA16u-480).

## Output Relay

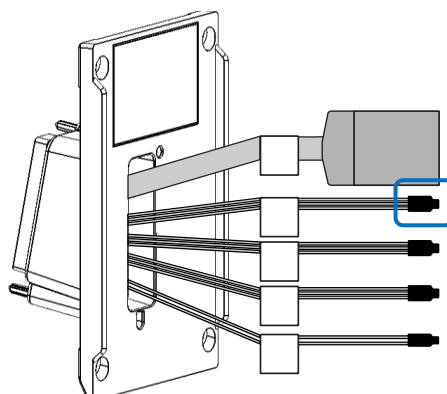

Figure 11: Output relay wiring

19	Yellow	Relay NO		Contact relay (normally open)
22	Grey	Relay COM		Contact relay common
21	Orange	Relay NC		Contact relay (normally closed)

### Nominal characteristics of relay

Load characteristics:

- 1 A max @ 30 VDC (according to the safety extra low voltage requirements independently of the power supply),
- Resistive load or inductive load; see warning information hereafter for inductive load.
- The internal relay is designed for at least 100 000 cycles.



**Inductive load management requires a parallel diode for a better contact lifetime.**

## Example of connection for electrical door locks

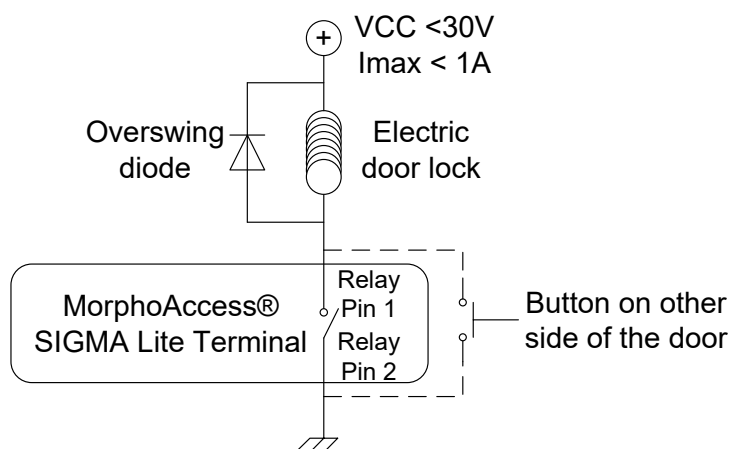

Figure 12: Example of electric door strike connection

## Tamper Switch

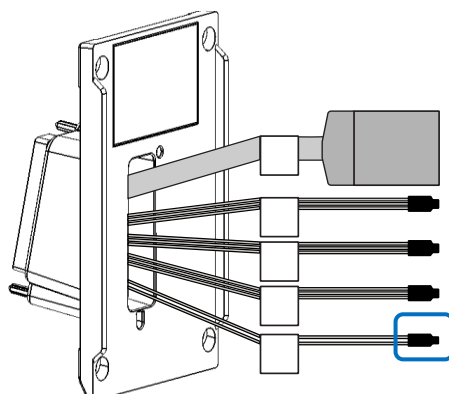

Figure 13: Tamper switch wiring

3	Light Blue	Switch 1		Tamper switch contact
4	Pink	Switch 2		Strip on tamper switch

### Operating principle for the switch

- Product installed on the wall plate: switch enabled (contact closed).
- Product opened (rear connectors accessible): switch disabled (contact open).

### Nominal characteristics of switch block

Electrical characteristics: 100 mA at 30 VDC max (Resistive load) according to the safety extra low voltage standard.



**This MorphoAccess® SIGMA Lite Series terminal is part of security system; it is customer's responsibility to connect the tamper switch (contact) to physical access controller, in order to detect unauthorized access to the connector blocks.**

## Wiegand port wiring

### Wiegand input wiring

The following figure shows how to cable the wires of the “Wiegand In” port of the terminal for Wiegand protocol. This is used, for instance, to connect an external card stripe reader to the MorphoAccess® SIGMA Lite terminal.

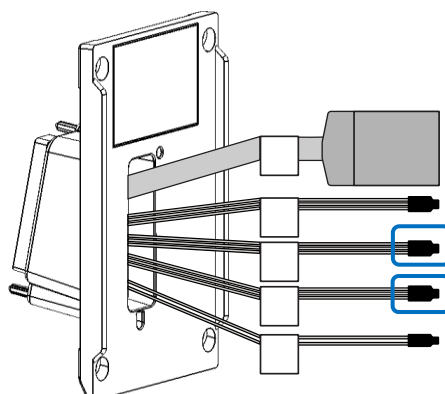

Figure 14: Wiegand input wiring

13	Green / Red	WIEGAND_IN0	In	Wiegand IN D0 (Output type required: Open drain or 5V+/-5%)
15	White / Red	WIEGAND_IN1	In	Wiegand IN D1 (Output type required: Open drain or 5V+/-5%)
11	Yellow	GPO0 (WIEGAND_LEDIN)	Out	Wiegand LEDIN (typical = 5VDC) (option)
20	Black / Red	WIEGAND_GND		Ground for Wiegand



If pull-up's to 12V have been added on D0\_IN and D1\_IN inputs on a previous installation with a MorphoAccess® 500 Series terminal, these resistors must be removed to avoid any damage to the MorphoAccess® SIGMA Lite Series terminal.

## Wiegand output wiring

The following figure shows how to cable the wires of the Wiegand OUT port of the terminal for Wiegand protocol. This is used, for instance, to connect the MorphoAccess® SIGMA Lite terminal to an Access Control Panel (ACP).

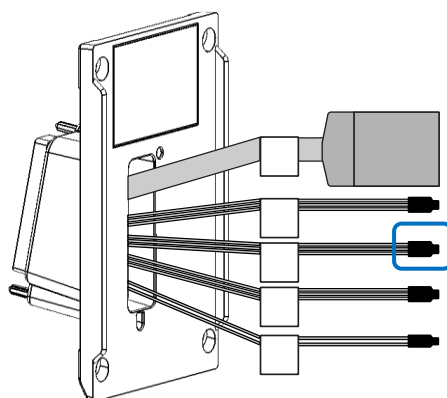

Figure 15: Wiegand output wiring

14	Green	WIEGAND_OUT0	Out	Wiegand OUT D0 (5V TTL)
16	White	WIEGAND_OUT1	Out	Wiegand OUT D1 (5V TTL)
17	Blue	WIEGAND_LEDOUT1	In	Wiegand LED IN 1 (option): panel feedback (Output type required: Open drain or 5V+/-5%)
18	Blue / Red	WIEGAND_LEDOUT2	In	Wiegand LED IN 2 (option): panel feedback (Output type required: Open drain or 5V+/-5%)
20	Black / Red	WIEGAND_GND		Ground for Wiegand

The use of LED IN 1 and LED IN 2 wires is described in the paragraphs below.

## The controller supports neither LED1 nor LED2 signals

When the access controller has no relay contact to provide an answer to the MorphoAccess® terminal, then the decision to emit either the “access granted” signal or the “access denied” signal is taken by another way. It is either the MorphoAccess® terminal itself that decide, or it waits for the access controller answer through the local area network (TCP), or on the RS-485 serial port.

It is strongly recommended to disable the LED IN feature, to avoid any interference on MorphoAccess terminal behavior.

## The controller supports only LED1 signal

When the access controller has only one relay contact which is dedicated to the “access granted” answer, this one must be connected between the LED1 and GND wires. The LED1 wire is set to the low level by closing the contact between the LED1 and the GND wires, and it means “access granted”.

The MorphoAccess® terminal uses the timeout of the wait for a low level on the on LED1 wire or LED2 wire as “access denied” answer.

To minimize at most the waiting time of the user, the MorphoAccess® SIGMA Lite Series terminal timeout value, must be adjusted to a value a little bit higher than the maximal value of the controller response time.

**Warning: if the LED2 wire is connected, it must be constantly maintained in the high state.**

## The controller supports LED1 and LED2 signals

When the controller supports one relay contact for each of the possible answers then:

- The « access granted » contact must be connected between the LED1 and the GND wires of the terminal
- The « access denied » contact must be connected between the LED2 and the GND wires of the terminal.

The MorphoAccess® terminal considers that:

- The answer of the controller is "access granted", when the controller puts the LED1 wire to the low state (by closing a contact between the LED1 and the GND wires), **and leaves the LED2 wire to the high state.**
- The answer of the controller is "access denied", when the controller puts the LED2 wire to the low state (by closing a contact between the LED2 and the GND wires), **whatever is the state of the LED1 wire.**

The MorphoAccess® terminal also considers that the answer of the controller is "access denied" in case of time-out while expecting for a closure between LED1 and GND wires, or between LED2 and GND wires.

## Data Clock Input

The following figure shows how to cable the wires of the “Wiegand In” port of the terminal for Data Clock protocol. This is used, for instance, to connect an external card stripe reader to the MorphoAccess® SIGMA Lite terminal.

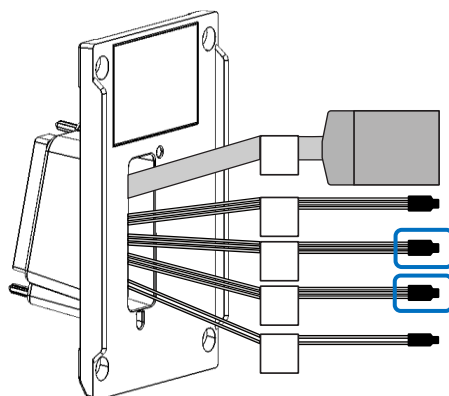

Figure 16: Wiegand port wiring – DataClock

13	Green / Red	WIEGAND_IN0	In	Data (Output type required: Open drain only)
15	White / Red	WIEGAND_IN1	In	Clock (Output type required: Open drain only)
11	Yellow	GPO0 (WIEGAND_LEDIN)	Out	Card present signal (if configured, only one selectable for Morpho Legacy)
20	Black / Red	WIEGAND_GND		Ground for Wiegand

## Data Clock Output

The following figure shows how to cable the wires of the Wiegand OUT port of the terminal for Data Clock protocol. This is used, for instance, to connect the MorphoAccess® SIGMA Lite terminal to an Access Control Panel (ACP).

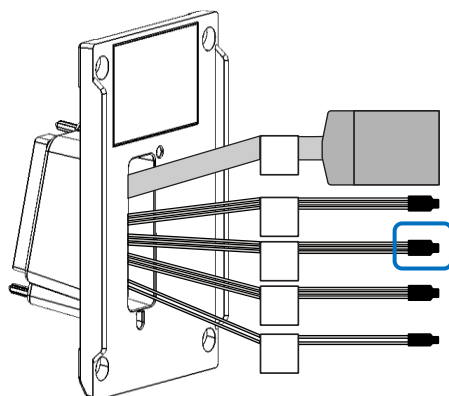

Figure 17: Wiegand port wiring – Data Clock

14	Green	WIEGAND_OUT0	Out	Data ( 5V TTL )
16	White	WIEGAND_OUT1	Out	Clock ( 5V TTL )
17	Blue	WIEGAND_LEDOUT1	In	Card present signal (if configured, only one selectable for Morpho Legacy)
18	Blue / Red	WIEGAND_LEDOUT2	In	Card present signal (if configured)
20	Black / Red	WIEGAND_GND		Ground for Wiegand

## RS-485 port wiring

The following figure shows how to cable the wires of the RS-485 OUT port of the terminal (RS-485 protocol). This is used, for instance, to connect the MorphoAccess® SIGMA Lite terminal to an Access Control Panel (ACP).

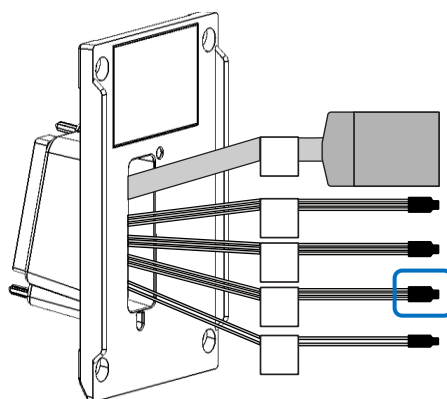

Figure 18: RS-485 port wiring – RS485

5	Blue	RS485_A	In/Out	RS485 Rx/Tx non inverting signal
7	Blue / Red	RS485_B	In/Out	RS485 Rx/Tx inverting signal
6	Black / Red	RS485_GND		Ground

RS485 implementation is limited to half-duplex communication. So only Tx+, Tx- and ground reference signals are necessary.

Depending on the RS485 network, an impedance adaptation may be required.

For farthest terminal, a 120-Ohms resistor termination may be added outside the terminal between Tx+ and Tx-.

## GPIO wiring

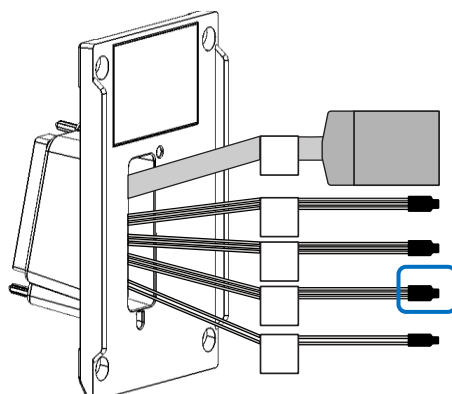

Figure 19: GPIO wiring

9	Orange	GPI_0	In	Digital Input (1,8V to 5V)
10	Orange / Red	GPI_1	In	Digital Input (1,8V to 5 V)
11	Yellow	GPO_0	Out	Digital Output (5V – 5mA max)
12	Yellow / Red	GPO_1	Out	Digital Output (5V – 5mA max)
8	Black / Red	GPIO_GND		Ground

## Single Door Access Control (SDAC) implementation

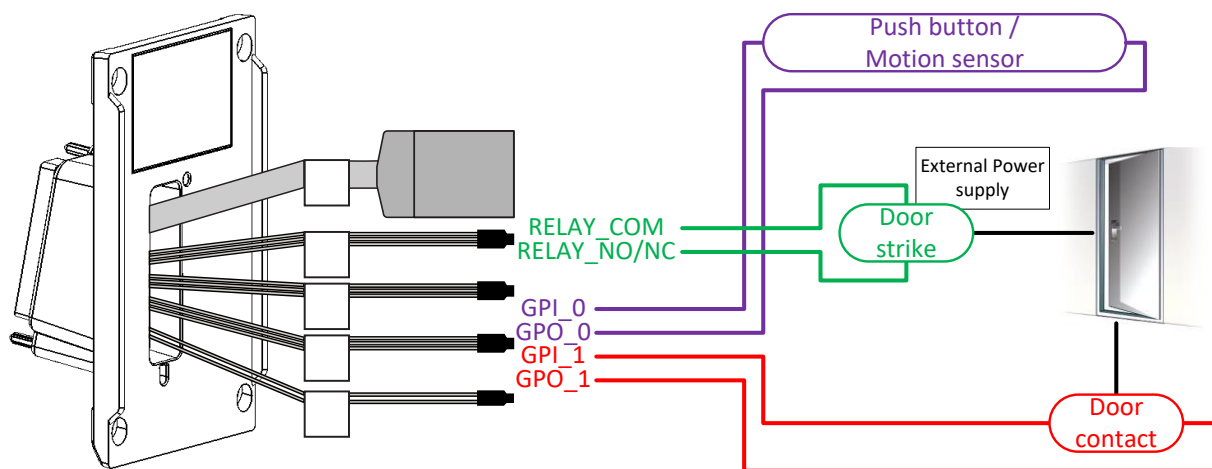

Figure 20: SDAC wiring



If door contact is not used, GPI1 and GPO1 shall be connected together

## Ethernet connection

Ethernet interface can be used to power the MorphoAccess® SIGMA Lite Series terminal through POE (Power Over Ethernet - IEEE802.3af or IEEE802.3at type 1 mode). According to the POE standard two modes are available: power on data pins and power on dedicated pins.

Use either one of these modes depending on POE implementation on your local Ethernet network.



**Wi-Fi™ dongle must not be used with POE power supply. The POE doesn't provide enough power for both the terminal and the Wi-Fi USB dongle.**



**Ethernet cable shall be shielded**

For UL 294 compliance the Ethernet Jack is for supplemental use.

### Default Ethernet configuration

By default, MorphoAccess® SIGMA Lite Series terminal is configured in Static mode

IP address Mode	Parameter	Factory value
Static	Terminal IP address	192.168.1.10
	Gateway IP address	192.168.1.254
	Sub network mask	255.255.254.0
	Host name	MAsigma-lite MAsigma-lite-plus

### Connecting MorphoAccess® SIGMA Lite Series terminal with default Ethernet configuration

Administrator must change the default Ethernet configuration before deploying terminal on site. This can be achieved by several ways as mention below.

- MBTB > Quick Configuration > Communication Configuration > IPv4 Address Settings
- MBTB > USB Script > Set IP configuration
- Webserver > Terminal Settings > Communication > IPv4 Network

Prior to connecting through MBTB or Webserver, please check if terminal is accessible from Host system/PC or not. To access terminal which is having default network parameter, the administrator may need to modify the network parameters of the Host PC.

Please refer to following example to connect terminal which is having default network parameter.



**Figure 21: Direct Point to Point Ethernet Connection**

1. Connect terminal directly to PC with Point to Point Ethernet connection.
2. Change the Host PC IP address to 192.168.1.11 (or any IP address within 192.168.x.x range excluding 192.168.1.10)
3. Connect terminal with its default IP address i.e. 192.168.1.10 either from MBTB or Webserver.
4. Change the Terminal network parameter from MBTB or Webserver.

**NOTE:** For connecting terminal directly to a PC (Point to Point connection) by an Ethernet cable, the Ethernet port of the PC must support the Auto-MDIX feature, otherwise a crossover Ethernet cable is mandatory. If no crossover Ethernet cable is available, then a dedicated switch can be used for the connection.

## Recommendations for RJ45 wiring

Pin	1	2	3	4	5	6	7	8
Signals	Data pair 1	Data pair 1	Data pair 2	NC/POE pin dedicated (+)	NC/POE pin dedicated (+)	Data pair 2	Ground/ pin dedicated (-)	NC/POE pin dedicated (-)
EIA / TIA T568B Colors	White orange	Orange	White green	Blue	White blue	Green	White brown	Brown
EIA / TIA T568A Colors	White green	White green	White green	White green	White green	White green	White green	White green
Corel L120 Colors	Grey	White	Pink	Orange	Yellow	Blue	Purple	Brown

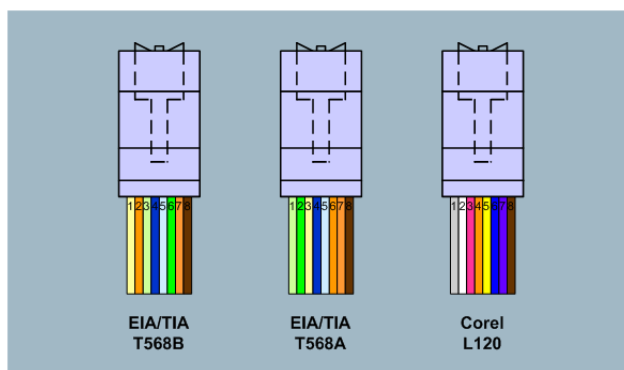

**Figure 22: RJ45 wiring**

RJ45 plug pinout is compliant with 10/100 base T, IEEE802.3 Specification. Product is compliant also with MDI or MDI-X.

## External USB connection

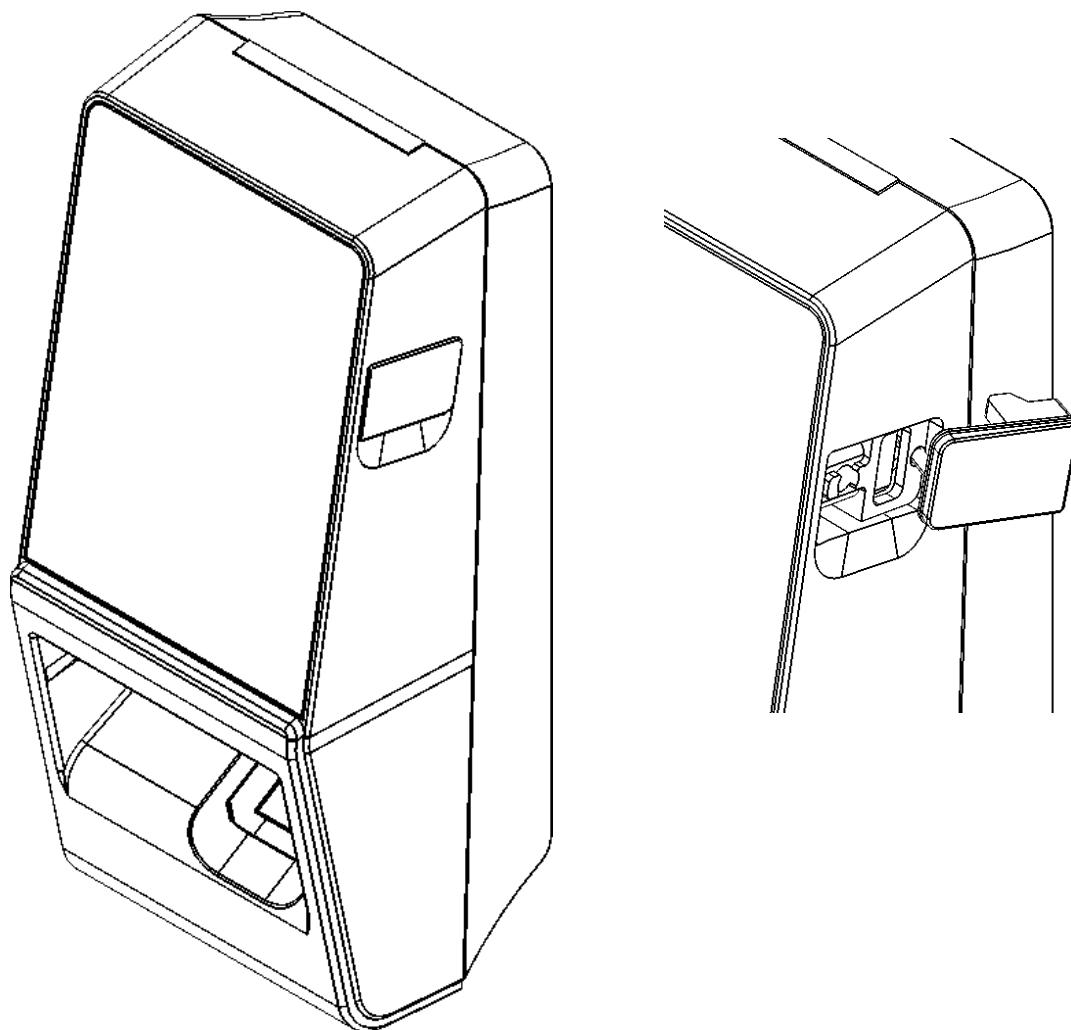

Figure 23: External USB connection

The external Micro USB port can be used to connect a mass storage USB key for administration only. This requires a standard Micro USB-type A / USB-type A female adapter or cable (which can be found in Morpho catalogue with ref 293658551).

Please report to the Administration Guide for more information.



**USB connection is limited to USB mass storage key connection (power consumption shall not exceed 200mA)**

## Wi-Fi™ dongle installation

Wi-Fi™ dongle shall be preferably installed outside the product (separate area shall be reserved in the wall) and connected to the internal USB Mini B (at the rear of the terminal) using Morpho cable provided in the kit.

Wi-Fi™ dongle shall not be exposed to temperature exceeding 50°C (don't forget to count the thermal dissipation of the product and of the Wi-Fi™ dongle).

Wi-Fi™ feature requires the product to be powered from an external DC 12V to 24V power supply (the POE doesn't provides enough power for both the terminal and the Wi-Fi™ dongle)

Only Wi-Fi™ dongle delivered by IDEMIA (kit reference 293686787) may be installed with the terminal for WLAN (Wireless Local Area Network) operation.

Cable has to be plugged on the upward USB connector of the rear panel, as on the following image:

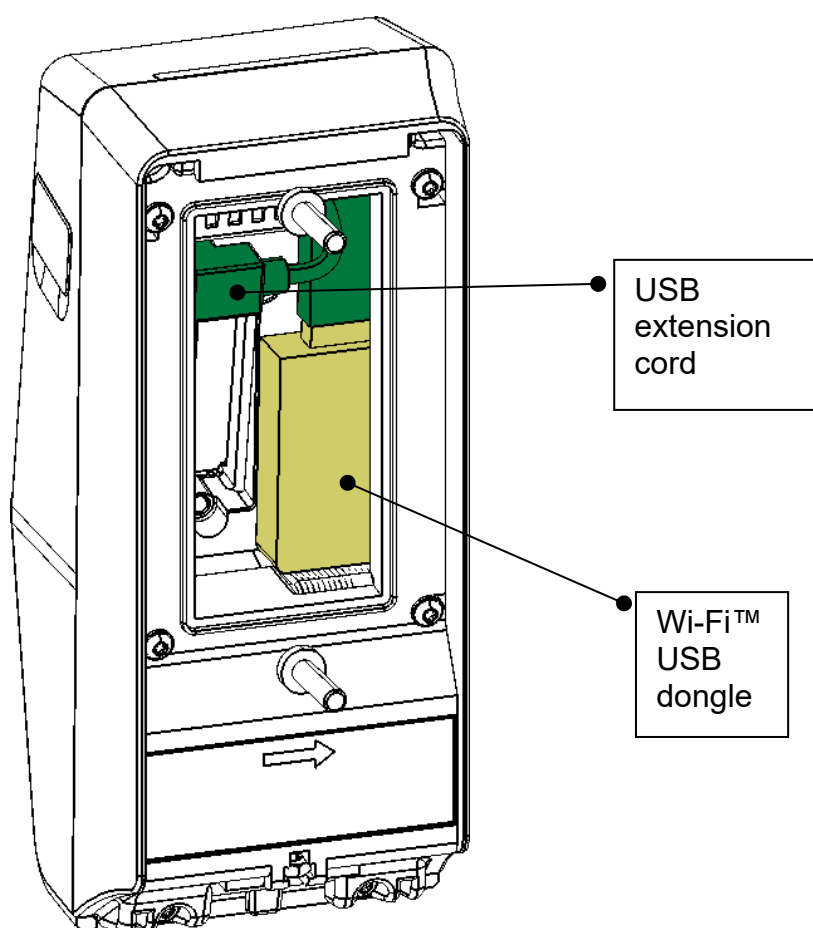

**Figure 24: Wi-Fi™ dongle installation**

Note: the Wifi dongle has not been UL evaluated.



## Modes for controlling access rights

### Introduction

The MorphoAccess® SIGMA Lite Series terminal offers several methods for controlling access rights: it needs to be configured in one of the following four modes:

- Identification mode,
- Authentication mode (requires a contactless smartcard reader in the terminal),
- Multi-factor mode (requires a contactless smartcard reader in the terminal),
- Proxy mode

Refer to the Administration Guide for more information on Access Control.

### Identification mode

The Identification process of the MorphoAccess® SIGMA Lite Series terminal proceeds by comparison of the biometric data of the finger placed on the biometric sensor, with all the biometric data stored in the database.

It means that the biometric data of the allowed users must be stored in the internal database before they can request the access on the terminal. This biometric data is acquired either directly on the terminal (using the embedded webserver application and the biometric sensor of the terminal), or on an enrolment system using a biometric sensor compatible with the terminal (such as MorphoSmart™ sensors).

The access control by identification process is started when a finger is detected on the biometric sensor

When the user requests the access, his identity is unknown, and it is the terminal that searches for his identity. The terminal grants the access if a match is found (the user is identified); otherwise the access is denied (the user remains unknown).

For further information, please see the "Identification mode" section in the Administration Guide.

### Authentication (verification) mode

Unlike the "identification" mode, the user identity must be known in order to execute the authentication process.

Indeed, authentication is an identity verification process: the user provides his identity and the terminal checks it with the relevant process.

This mode doesn't compare the user's data to the data of several users: it compares the data provided by the user with the reference data provided by the same user during enrollment phase. The data can be on a card presented to the terminal or in a database and ID is provided by the user.

Access is authorized if the terminal finds a correspondence.

For further information, please see the "Authentication mode" section in the Administration Guide.

## Multi-factor mode

In this mode, the "identification" and "authentication" modes are available simultaneously; the user decides which control method will be used:

- by placing his finger on the sensor, thereby triggering the identification process,
- by placing his contactless card on the reader, thereby triggering the authentication process,

This is the default mode for terminals fitted with a contactless smartcard reader.

For further information, please see the "Multi-factors method" section in the Administration Guide.

## Proxy mode

The Proxy mode is an operating mode where the access control main application is located in a distant system. This is not a standalone mode like Identification and Authentication modes.

It means that the terminal becomes a slave of the host system application. The access control application is running on the host system and uses MorphoAccess® SIGMA Lite Series terminal high level functions:

- Identification function
- Authentication function
- Read data on a contactless card
- Access control result signal command

The MorphoAccess® SIGMA Lite Series terminal is driven through an Ethernet (or Wi-Fi™) link using TCP, SSL or TLS protocol.

The MorphoAccess® SIGMA Lite Series terminal acts as a server: it is either waiting for a command or executing a command.

The commands allowed by the MorphoAccess® SIGMA Lite Series terminal are described in the Host System and Remote Message Interfaces document.

For further details about SSL or TLS on the MorphoAccess® SIGMA Lite Series terminal, please refer to the Administration Guide.

## External database mode (also called polling mode)

The reference biometric templates of the users are stored in external database, instead of terminal local database or user's RF card.

When authentication is initiated on the terminal, the terminal will poll the user ID to external controller. On polling out the ID, the corresponding template (if exists) is fetched from the external database and is authenticated against user's biometric on

the terminal. Once the template request is posted to the external database, the terminal shall wait for the finger template from the external database to start authentication. Further process shall be same as authentication.

#### **Polling Process using buffer:**

- The user's input ID will be queued in the terminal's queue, which is polled by external application.
- External application waits for the User ID by polling the buffer. After getting a user ID, it will search the template in database and send template to terminal for further authentication.
- The user is authenticated by the external device and granted access accordingly.

MorphoAccess® SIGMA Lite Series terminal also has distant commands to retrieve polling buffer status and polling buffer data. Refer to the Host System and Remote Message Interfaces document.

#### **How to Activate?**

External database mode can be activated through Webserver > Complete Configuration, by setting "ucc.enable\_external\_database" parameter to 1. Only an admin user can activate polling mode. You can refer to the Host System and Remote Message Interfaces document to know how to set this parameter.

**NOTE:** When terminal is in L1 legacy mode, then polling mode can be configured using SecureAdmin application.

## Configuring the terminal

MorphoAccess® SIGMA Lite Series terminals are standalone biometric systems which offers advance features for access control. MorphoAccess® SIGMA Lite Series terminals are equipped with a facility to support the MorphoAccess® and Bioscrypt legacy systems.

When MorphoAccess® SIGMA Lite Series terminal is set in any of the legacy modes, it supports the database structures and configurations of the selected legacy system. When the terminal is booted for the first time, user can select any of the following modes:

### MorphoAccess® 500 or J Series legacy mode

MorphoAccess® SIGMA Lite Series terminal can be operated in MorphoAccess® 500 or J series mode (also referred as Legacy Morpho). In this mode, the terminal will support configurations and operations of MorphoAccess® 500 series terminals. Terminal can authenticate users enrolled in the MorphoAccess® 500 series terminal, using biometric check as well as contactless card. New users can also be enrolled in MorphoAccess® 500 series mode.

Once the product is configured in Legacy Morpho mode, the following methods can be used to configure the terminal:

- through the Ethernet interface (remote management)
- through a Wi-Fi™ connection (license and dongle required)

Configuration procedures are described inside the Administration Guide document in “Terminal Configuration And Administration” section.

### Bioscrypt 4G Series legacy mode

MorphoAccess® SIGMA Lite Series can be operated in Bioscrypt 4G mode (also referred as Legacy L1). In this mode, the terminal will support limited operations and configurations that are done using Secure Admin application. The terminal in L1 mode is able to authenticate the users enrolled on 4G terminals and contactless cards. However it is not possible to enroll users in legacy L1 mode on MorphoAccess® SIGMA Lite Series terminal.

In case, users are enrolled in MA5G mode, the user data cannot be exported when terminal is in L1 mode.

Once the product is configured in Legacy L1 mode, the following methods can be used to configure the terminal:

- through the Ethernet interface (remote management)
- through a Wi-Fi™ connection (license and dongle required)

Configuration procedures are described inside the Administration Guide document in “Terminal Configuration And Administration” section.

## MorphoAccess® SIGMA Lite Series native mode

MorphoAccess® SIGMA Lite Series terminal is by default configured in native mode, also named MA5G. It will support the new features and configurations only in the native mode. The terminal can be configured using an internet browser connected to the embedded Webserver application.

**NOTE:**

- *When terminal mode is switched from MA5G to any of the legacy modes, the entire configuration (excepted communication links) and all databases are erased*
- *The terminal is rebooted on mode change and factory settings are applicable.*

Once the product is configured in native mode, the following methods can be used to configure the terminal:

- through the Ethernet interface (remote management)
- through a Wi-Fi™ connection (license and dongle required)

Configuration procedures are described inside the Administration Guide document in “Terminal Configuration And Administration” section.

## Anti-tamper / anti-pulling switches

Please refer also to “Tamper Switch” section.

These switches are activated as soon as there is enough pressure applied on the terminal against the wall. They are deactivated as soon as this pressure is not big enough, e.g. when the terminal is pulled out of the wall.

When the switches are deactivated, the MorphoAccess® SIGMA Lite Series terminal acts as required by the related configuration key (see Administration / Parameters Guide for key configuration description):

- Ignore the event (default): useful during normal maintenance operations.
- Send an alarm message to the Central Access Controller, through the usual channel of the access control result messages (Wiegand, DataClock, RS485, Ethernet or Wi-Fi™). An alarm switch (relay contact) is directly available on block terminal «tamper switch pins». Please refer to “Wiring overview” and to “Tamper Switch” sections.
- Generate an audible alarm signal with the speaker and an alert message on the screen.



---

## Compatible Accessories, Licenses and Software

The following items can be ordered directly to IDEMIA or to an official distributor, so as to enjoy all the features of your MorphoAccess® SIGMA Lite Series terminal:

- **Power supply units,**
- **Contactless smartcards:** MIFARE® 1k, 4k; DESFire® 2k, 4k, 8k,
- **MA WI-FI PACK:** containing a Wi-Fi™ USB dongle to activate Wi-Fi™ capability on your terminal,
- **User database size license (MA\_3K\_USERS, MA\_10K\_USERS):** enabling database size upgrade from 500 to 3,000 or 10,000 users capacity (max 3 fingers per record) at creation of the database.

**NOTE:** UL LLC has not verified the Wifi, LAN, RS485 ports.

## Compatible PC applications

MorphoAccess® SIGMA Lite Series terminals are fully compatible with:

- MorphoManager (version 8.0.3 or higher),
- Morpho Integrator's Kit (MIK) software development kit (version 6 or higher),
- MorphoBioToolBox (version 2 or higher).

Using Legacy Morpho mode, MorphoAccess® SIGMA Lite Series is also compatible with:

- MEMS (version 7.3.1 or higher),
- MIK (version 5.4 or higher),

The limitations in Morpho Legacy mode are described in the Application Notes – Morpho Legacy Mode Limitations.

Using Legacy L1 mode, MorphoAccess® SIGMA Lite Series is also compatible with:

- SecureAdmin (version v4.1.20.0.1.0.0 or higher),

The limitations in L1 Legacy mode are described in the Application Notes – L1 Legacy Mode Limitations.



## Global warning

The manufacturer cannot be held responsible in case of non-compliance with the following recommendations or incorrect use of the terminal.

## General precautions

- Do not attempt to repair your terminal yourself. The manufacturer cannot be held responsible for any damage/accident that may result from attempts to repair components. Any work carried out by non-authorized personnel will invalidate your warranty.
- To ensure the proper operation of the product and prevent image retention on LCD screen, it is highly recommended not to display a static image on the screen for extended periods of time and to configure the device to repeatedly refresh the image displayed on the screen. Please note that image retention on LCD screen is considered improper use of the product and is not covered by the product warranty.
- Do not expose your terminal to extreme temperatures.
- Use your terminal with original accessories. Attempts to integrate unapproved accessories to the terminal will void your warranty.
- Due to electrostatic discharge, and depending on the environment, synthetic carpet should be avoided in areas where the terminal has been installed.
- To ensure the proper operation of the product and prevent degradation due to overvoltage, it is highly recommended to protect the devices with external accessory. Typically, risks of overvoltage have been identified on external power management wire, POE connector and wiegand input wire.

## Areas containing combustibles

It is strongly recommended that you do not install your terminal in the vicinity of gas stations, petroleum processing facilities or any other facility containing flammable or combustible gasses or materials.

## Specific precautions for terminals equipped with a contactless smartcard reader

It is recommended to install terminals equipped with a contactless smartcard reader at a certain distance (> 30cm) from metallic elements such as iron fixations or lift gates or radio product (such as contactless smartcard reader). Performances in terms of contactless badge reading distance will decrease when metallic elements are closer.

## Ethernet connection

It is recommended to use a category 6 shielding cable (120 Ohms). It is also strongly recommended to insert a repeater unit every 90m.

Extreme care must be taken while connecting Ethernet wire to the terminal block board since low quality connection may strongly impact Ethernet signal sensibility.

It is recommended to connect Rx+ and Rx- with the same twisted-pair wire (and to do the same with Tx+/Tx- and the other twisted-pair wire).

## Date / Time synchronization

The terminal clock has a +/-10 ppm typical time deviation at +25°C (roughly around +/- 6 sec per 48 hours). At lower and higher temperature (but within normal operating temperatures), deviation may be more important (worst case: - 14 seconds per 48 hours).

If the terminal is used in an application requiring high time precision, we recommend synchronizing regularly your terminal time with an external clock (using NTP). Every 24 hours is usually enough for most applications.

Please note that the date/time of the terminal is protected from power failure during at least 24 hours. If the duration of the power failure or power down is longer, the date/time of the terminal will be lost.

## Cleaning precautions

The use of a dry cloth is recommended to clean the terminal, especially the biometric sensor.

## Disinfection and sanitization recommendations

- 1- Moisten a non-abrasive wipe (such as Economizer® Wipers or 3M Scotch-Brite® High Performance Cloth) with the following disinfectants:
  - Windex® Multi-Surface Disinfectant or another similar product containing L-Lactic acid.
  - Hydrogen peroxide (< 3%).
- 2- Wipe the device's surface and leave the surface wet with disinfectant for at least 5 minutes

### **Important notice:**

The following practices permanently damage and/or negatively impact the performances of the device:

- Do not use bleach or disinfectants containing aggressive substances such as chlorine, soda, alcohol, quaternary ammonium etc
- Do not spray directly on the biometric sensor or the casing of the terminal
- Do not use abrasive cloths or wipes (e.g., paper towels)

## Legacy mode

When terminal mode is switched from MA5G mode to any of the legacy modes, the entire configuration (except communication links) and all databases are erased.

The terminal is rebooted on mode change and factory settings are applicable.

Firmware legacy limitations are described in the MorphoAccess® SIGMA Lite Series Release Note.

Hardware legacy differences are described below:

### Power supply

	4G Lite Series	MA-J Series	MA SIGMA Lite Series
DC power supply	12V – 24V (-15% / +10%)	12V (-15% / +30%)	12V – 24V (-15% / +10%)
DC power supply connection	Wires	Terminal block	Wires
Power supply by POE	Only for CR Pass (IEEE802.3af compliant)	IEEE802.3af compliant	IEEE802.3at type 1 compliant
POE power supply connection	RJ45 connector or wires	Block connector and RJ45 connector	RJ45 connector or wires

Note: Only the MA sigma Lite series was evaluated by UL.

### Ethernet communication

4G Lite Series	MA-J Series	MA SIGMA Lite Series
RJ45 connector or wires	Block connector RJ45 connector	RJ45 connector or wires

### Serial communications

	4G Lite Series	MA-J Series	MA SIGMA Lite Series
Wiegand	Yes <ul style="list-style-type: none"> <li>Output port</li> <li>Input port</li> </ul> No LED IN/OUT port	Interfaces multiplexed on the same lines. Wiegand, Dataclock and RS-485 (Half duplex) protocols shall only be enabled at one time, else priority is given to Wiegand, then Dataclock, then RS485.	Yes <ul style="list-style-type: none"> <li>Output port</li> <li>Input port</li> <li>LED OUT port</li> <li>LED IN by GPO</li> </ul>
Dataclock	No		Yes
RS-485	Half duplex (Slave only)	<u>Wiegand</u> : Output port only + LED IN inputs <u>Dataclock</u> : Output port	Half duplex (Slave only)

### GPI/GPO

	4G Lite Series	MA-J Series	MA SIGMA Lite Series
GPI	2 GPI	No	2 GPI
GPO	1 GPO (1 TTLOUT_H and 1 TTLOUT_L)	No	2GPO (≈ 2 TTLOUT_H only)
GPO current limitation	5mA@5V for 4G	-	5mA@5V

## RELAY

	4G Lite Series	MA-J Series	MA SIGMA Lite Series
Relay pins available	NO / NC / COM*	NO / COM	NO / NC / COM
Driver capability	1 A @30V DC (Resistive load)	1 A @30V DC (Resistive load)	1 A @30V DC (Resistive load)

\*: NO: Normally open

NC: Normally closed

COM: Common

## RS232 communication

4G Lite Series	MA-J Series	MA SIGMA Lite Series
Not available	Not available	Not available

## Anti theft/ Tamper switches

	4G Lite Series	MA-J Series	MA SIGMA Lite Series
Anti theft switch	No	Yes	Yes
Tamper switch	Yes	Yes	Yes
Warning to a host if the product isn't supplied	No	Yes	Yes



## Main principles

Acquisition needs to be done with extreme care, in order to:

- get the best image quality
- increase recognition performance
- reduce recognition time

Then, it is highly recommended to:

- Maximize the contact between the fingerprint and the sensor
- Exert firm, but not excessive, finger pressure on the surface of the sensor
- Do not press too hard
- Do not slide nor roll the finger across the sensor
- Do not move the finger during acquisition
- Wait for the extinction of sensor backlight before removing the finger

## Most useful areas for biometric data

Fingerprint central area must be aligned with sensor center.

Area containing  
the maximum  
information



## Position of finger

### Finger height

Align center of 1<sup>st</sup> phalanx with sensor center

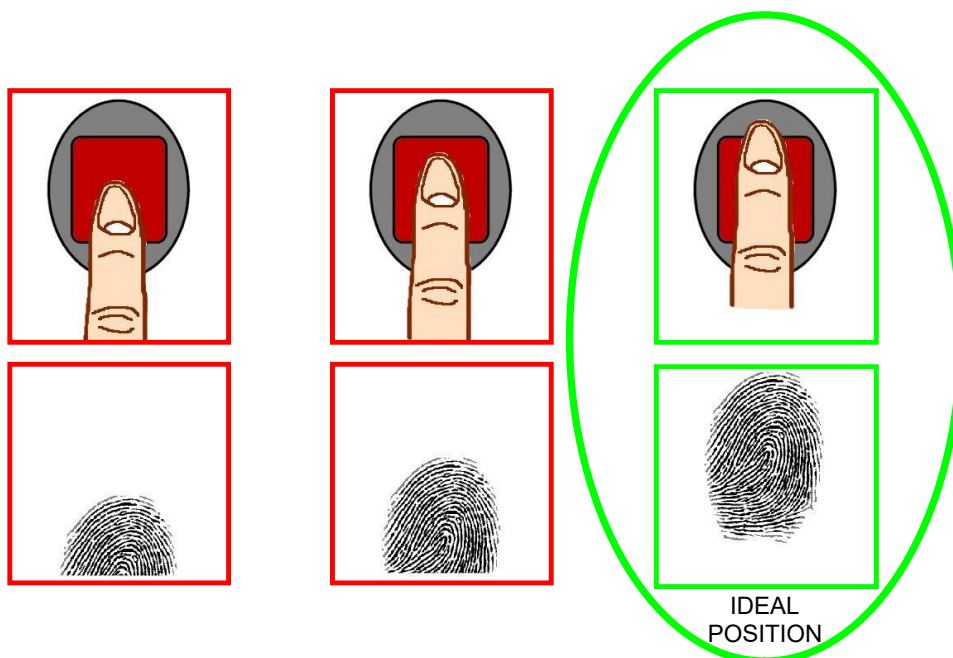

### Finger angle

The finger must be parallel to sensor sides

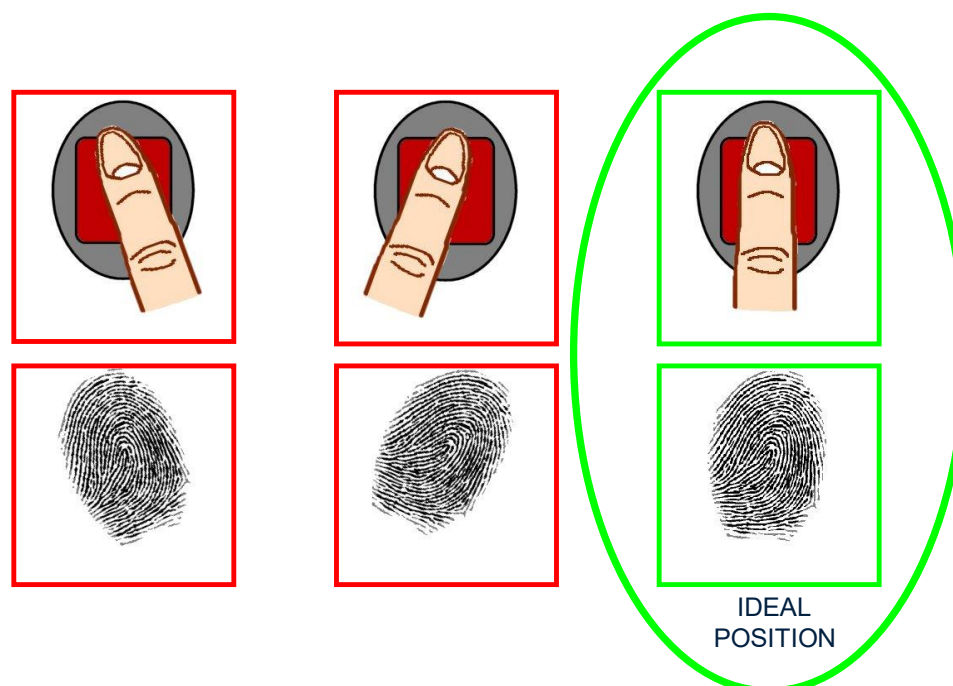

## Finger inclination

Finger must be parallel to the sensor surface

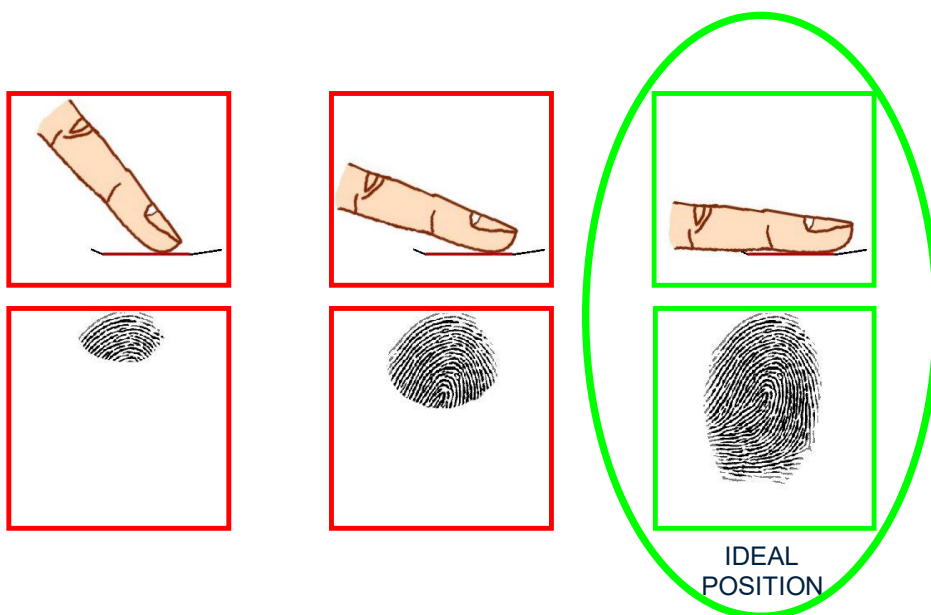

## Finger rotation

Finger must be parallel to the sensor surface

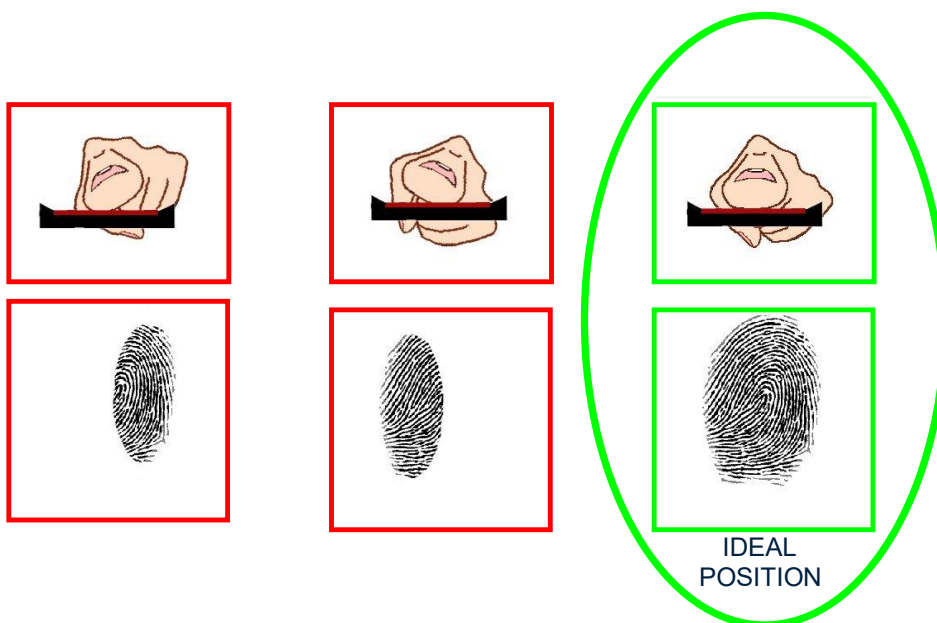

## Troubleshooting

When finger biometric data acquisition is difficult, please follow the recommendations listed below:

- The finger is cold
  - Solution : warm up the finger
- The finger is wet
  - Solution : wipe the finger
- The finger is dry
  - Solution : warm up the finger and/or add a little bit of humidity
- The finger is dirty
  - Solution: wash hands
- Remove bandages or adhesive tapes from the fingerprint area,
- Do not press or tense finger to avoid blood vessels constriction



---

## How to get the latest versions of documents

The last version of the documents can be downloaded from our web site at the address below:

[www.biometric-terminals.com](http://www.biometric-terminals.com)

(Login and password required to allow access to the private part).

To request a login, please contact your sales representative.

---

## Documents concerning the MorphoAccess® terminal

### *Documents about installing the terminal*

#### **Quick Installation Guide,**

This document describes the main steps for wall mounting.

#### **Installation Guide,**

This document describes the terminals physical mounting procedure, electrical interfaces and connection procedures.

#### **Recommendations for Secure Installation,**

This document describes all actions to secure your installation (physical installation, network, secure protocols etc.).

### *Documents about administrating / using the terminal*

#### **Quick User Guide,**

This document is the main guide that is used for learning the main steps for initializing the terminal operations.

#### **Administration Guide,**

This document describes the different functions available on the terminal and the procedures for configuring the terminal.

#### **Parameters Guide,**

This document contains the full description of all the terminal configuration parameters.

### *Documents for the developer*

#### **Contactless Card Specification,**

This document describes the contactless cards supported by the terminal and the format of the data on the contactless card.

#### **Host System and Remote Message Interfaces,**

This document describes the commands, the protocols, and the format of the data supported by the terminal.

#### **Distant Commands Guide,**

This document describes thrift commands supported by the terminal.

### *Release notes*

For each firmware version, a release note is published describing the new features, the supported products, the potential known issues, the upgrade / downgrade limitations, the recommendations, the potential restrictions...



## Troubleshooting

### **The terminal IP address is unknown or it is not possible to connect to the terminal**

Load a valid set of network parameters in your terminal.

### **The sensor is switched off**

Check that the database contains at least one record.

Check that the identification mode is enabled.

### **The terminal returns erratic responses to Ping commands**

Check the subnet mask.

Ask the network administrator for the correct value.

Check that each device connected to the network has a different IP address.

---

## Technical Support and Hotline

### North America

Mail: [support.bioterminals.us@idemia.com](mailto:support.bioterminals.us@idemia.com)

Tel: +1 888 940 7477

### South America

Mail: [support.bioterminals.us@idemia.com](mailto:support.bioterminals.us@idemia.com)

Tel: +1 714 575 2973

### Asia, Pacific

Mail: [support.bioterminals.in@idemia.com](mailto:support.bioterminals.in@idemia.com)

Tel: +91 1800 120 203 020

### Europe, Middle East and Africa

Mail: [support.bioterminals@idemia.com](mailto:support.bioterminals@idemia.com)

Tel: +33 1 30 20 30 40

(9H00am to 5H30pm French Time, Monday to Friday)

### Web site

For the latest firmware, software, document releases, and news, please check our website [www.biometric-terminals.com](http://www.biometric-terminals.com) (To get your login and password please contact your sales representative).

COPYRIGHT© 2026 IDEMIA



Head office:

**IDEMIA**

2, place Samuel de Champlain

92400 Courbevoie - France

[www.idemia.com](http://www.idemia.com)